

*THIS BOOK WILL HELP YOUR OPERATOR
SEE THAT HE GETS IT*

Instruction Book 84772
Supersedes 84700A

**SPRAGUE G-E MULTIPLE UNIT CONTROL
TYPE PC**

When ordering supplies specify "General Electric"

GENERAL ELECTRIC COMPANY
SCHENECTADY, N. Y.
OCTOBER, 1922

CONTENTS

	PAGE
General	4
Automatic Control.....	4
Operation of Motor Controller.....	4
Equipment	5
Installation	6
Controller Supports.....	6
Insulating from Ground.....	6
Air Piping.....	6
Main Fuse Box.....	16
Control Coupler Sockets and Plugs.....	16
Motor Resistors.....	16
Sequence of PC Controllers.....	18
Sequence for PC-5 and PC-6 Controllers.....	18
Sequence for PC-9 Controller.....	18
Sequence for PC-10 Controller.....	20
Sequence for PC-12 Controller.....	20
Sequence for PC-101 Controller.....	20
PC-5, PC-6 and PC-9 Controllers	21
Contactor Units, Control Drum and Cam Shaft.....	21
Line Breaker.....	21
Reverser.....	21
PC-10 and PC-12 Controllers	21
Contactor Units.....	21
Control Drum.....	22
Cam Shaft and Pinion.....	22
Line Breaker.....	22
PC-101 Controller—1500 Volts.....	22
Main Engine	22
Removing Piston Spring.....	22
Replacing Piston Spring.....	23
Accelerating Relay	29
Normal Operation.....	29
Emergency Operation.....	29
Use of the Bypass Feature for Testing the Control.....	30
Maintenance	30
Operating Test.....	30
Inspection	30
Master Controller.....	30
Control Switches.....	30
Main Switch and Fuse Box.....	30
PC Controller.....	30
Contactor and Line Breaker.....	31
Reverser.....	31
Control Fingers.....	31
Overload Relay.....	31
Current Limit Relay.....	31
Control Drum.....	31
Star Wheels.....	32
Magnet Valves.....	32
Measuring Air Gap and Travel.....	32

	PAGE
Installing and Adjusting New Valves	33
Reverser, Line Breaker and "ON" Magnet Valves.....	33
Adjusting "OFF" Magnet Valve.....	33
Lubrication	34
Air Engines.....	34
Bearings.....	34
Overhauling Period	37
Air Engine.....	37
Ball Bearings.....	37
Sleeve and Spherical Bearings.....	37
Accelerator Valve for Small PC Controllers	37
Gauges and Wrenches—PC Equipments	37
Cables for Car Equipment	39
Type C-6 Feed Valve	40
Description of Valve.....	40
Operation.....	40

SPRAGUE G-E MULTIPLE UNIT CONTROL

TYPE PC

GENERAL

The Sprague General Electric multiple unit control system was designed primarily to permit a train of motor cars, when coupled in any combination, to be operated as a single unit from either end of any car of the train.

The system has been very generally used on individual equipments where it has been desired to remove from the car platform all apparatus carrying motor current.

Fundamentally, the system for each motor car may be considered as consisting of a motor controller and a master controller. The motor controller comprises a set of apparatus which handles directly the current for the motors, while the master controller merely governs the operation of the motor controller, and consequently, does not handle the larger currents necessary in the motor circuit.

The latest development in the Sprague General Electric multiple unit control system is the cam-operated motor controller, known as Type PC. Before designing this controller, a thorough analysis of all existing control systems was made. The result is the following improvements in design and operation:

1. A definite sequence of contactor operation, preventing the trouble sometimes encountered from improper functioning of independently operated contactors.
2. Interlocks on individual contactors eliminated.
3. Simplicity of electric control circuits.
4. The contactor arc chutes assembled in a single group that swings downward, exposing all contactor parts.
5. The simplicity and compactness of the apparatus, which permits the assembly of the contactors, reverser, line breaker, relays, etc., in one box.
6. Less weight.

In general, car equipments may be divided into two classes, one being for city and light interurban service, and the other for elevated, subway and heavy interurban work. To furnish car equipments that will be best adapted to these services, Type PC controllers are manufactured in two sizes, for both two-motor and four-motor equipments. In designing the small PC controller, particular attention was given to the restricted space available for equipment underneath the modern car with low steps and small wheels.

At the same time, all the ruggedness, accessibility and safety features of the large PC controller are maintained in the smaller size.

AUTOMATIC CONTROL

The cam-operated contactors with their definite sequence of opening and closing and elimination of electrical interlocks makes possible the design of an automatic control that is simpler than former non-automatic types.

With automatic control, the master controller operates directly through the train wires, the motor reverser, line breaker and the rotation of the cam shaft closing the contactors for the first step, but the succeeding positions of the cam shaft and closing of the contactors is controlled indirectly by the master controller through the current limit relay and under its direct control.

The scheme of operation is that, as each section of resistance is cut out of circuit, an increased current passes through the motor and series coil of the current limit relay. If this current is sufficient to open the relay contacts, the progression of the cam shaft is arrested until the current falls to a predetermined value, and, in this manner, the automatic current limiting feature is secured.

One of the objections to automatic control has been the inflexibility of the current limit in so far as overcoming grades, pulling a dead car or other emergency conditions. The General Electric Company have overcome these objections by devising an automatic control from which the same results may be obtained as a non-automatic control under emergency conditions.

When a car will not accelerate at the current the notching relay is set, the operator moves the advance lever on the controller cap plate forward. This will advance the motor controller one point. This operation is repeated for succeeding notches. By this means the motor controller may be notched up to and held on any point desired, as may be done with a non-automatic control.

OPERATION OF MOTOR CONTROLLER

The line breaker, reverser and contactors are actuated by air pressure controlled by magnet valves. The line breaker and reverser are provided with individual magnet valves

and air cylinders, while a single cylinder with a double piston and two valves is used for the operation of all the contactors. The contactors are actuated by cams mounted on a shaft, which is rotated by a rack and pinion, as shown in Fig. 1. Air is admitted to, or exhausted from, the air cylinder, by means of magnet valves, controlled by the master controller.

EQUIPMENT

The list of apparatus comprising a complete PC control equipment for multiple unit operation is as follows:

600 Volts

- 2 Master controllers,
- 1 PC motor controller with bolt insulators,
- 2 Master control and reset switches,
- 1 Switch and fuse for the control circuits,

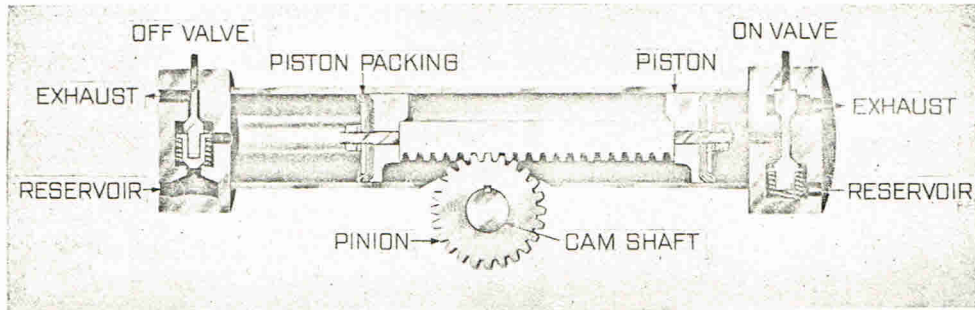

Fig. 1. Diagram Section of PC Controller Main Engine and Magnet Valves

Fig. 1 shows the position of the magnet valves and the pistons when the master and motor controllers are in the "off" position. In this position, the air pressure is applied to the "off" piston through the "off" magnet valve, while the "on" magnet valve allows any air in the "on" cylinder to pass through to atmosphere. When the master controller is turned on, and the reverser throws, the line breaker closes, and then both the "on" and "off" magnet valves are energized. This applies air pressure to the "on" piston and allows air to escape from the "off" cylinder; the rack moves toward the "off" magnet valve, rotating the pinion and cam shaft until the "off" magnet valve is de-energized. When this occurs air pressure is applied to the "off" piston, and, as the "on" magnet valve applies air pressure to the "on" piston, all movement of the rack and pinion ceases with the motor controller in the first operating position. Subsequent positions on the motor controller are obtained by alternately energizing and de-energizing the "off" magnet valve. When the master controller is turned off, the "on" and "off" magnet valves are de-energized and air pressure is applied to the "off" piston and released from the "on" piston. This causes the rack to move toward the "on" magnet valve and rotates the pinion and cam shaft, turning the motor controller to the "off" position.

- 1 Set control coupler sockets,
- 1 Control jumper,
- 1 Set air accessories,
Necessary control cable,
- 2 Current collectors
- 1 Main switch in box,
- 1 Lightning arrester,
- 1 Main fuse box,
- 1 Set cast grid motor resistors with bolt insulators,
Main motor wiring,
Car lighting material.

1200 and 1500 Volts

- 2 Master controllers,
- 1 PC motor controller with bolt insulators.
- 1 1½-kw. motor-generator with 32-volt generator for control, lights and headlight.
- 2 Master control and reset switches with fuses,
- 1 Set control coupler sockets,
- 1 Control jumper,
- 1 Set air accessories,
Necessary control cable,
- 2 Current collectors,
- 1 Main switch in box,
- 1 Lightning arrester,
- 1 Main fuse box,
- 1 Set motor resistors with bolt insulators,
Main motor wiring,
Car lighting material,
- 1 Change-over device (when operation on 600 volts is required).

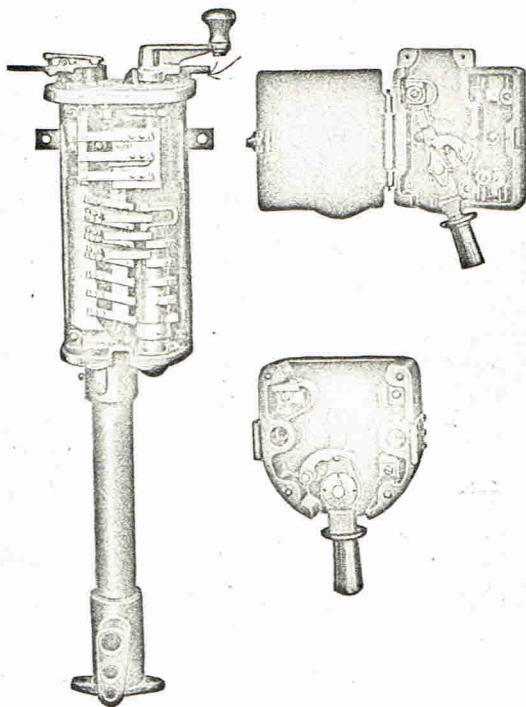

Fig. 2. Type C-129 Controller

INSTALLATION

CONTROLLER SUPPORTS

Previous Sprague General Electric control systems have been made up with each contactor a self-contained unit and no particular care in lining up the car-body supports was necessary. With the PC controller, in which all contactors are operated from a cam shaft, it is essential that the supports attached to the car-body, from which the controller is suspended, be accurately installed, as otherwise, the controller framework will be pulled out of shape and prevent the controller operating in a satisfactory manner. The points of support should not vary more than $\frac{1}{8}$ inch from one plane. Poor alignment may be indicated by the cam shaft not rotating at 45 pounds air pressure, or controller may start slowly and pass beyond the point where it should stop.

INSULATING FROM GROUND

The PC controller is arranged to be insulated from ground and clearance should be provided between all grounded pipes, hangers, brake rods, etc., and the metal box of the PC controller.

The insulation between the supports and the controller should be installed so that the bolts fastening the controller to its supports are not grounded. The method of insulation recommended is shown in Fig. 23.

The insulating joint used in the air pipe should be placed in a vertical pipe to prevent water collecting on the interior insulating surface.

When a PC controller is installed without a cover over the line breaker arc chutes, there should be at least 18 in. to any grounded metal directly in front of the arc chute and at least 8 in. to any grounded metal adjacent to the top or sides of the arc chutes. If grounded pipes or rods are nearer than 18 in., they should be covered with sufficient insulation to give this distance. When such insulation is used, it should extend at least 3 in. beyond the outside vertical edges of the arc chutes.

AIR PIPING

For air brake operation, it is ordinarily recommended that the air piping from the compressor be arranged to condense moisture contained in the air. For compressors of 25 cu. ft. per min. capacity, not less than 25 ft. of cooling pipe is used. With compressors of larger capacity, a greater amount of cooling pipe is required.

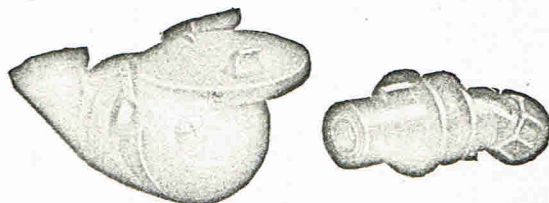

Fig. 3. Bus Line Coupler Socket and Plug

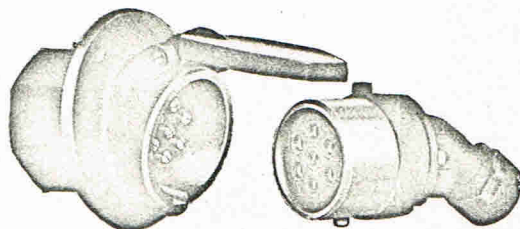

Fig. 4. Train Line Coupler Socket and Plug

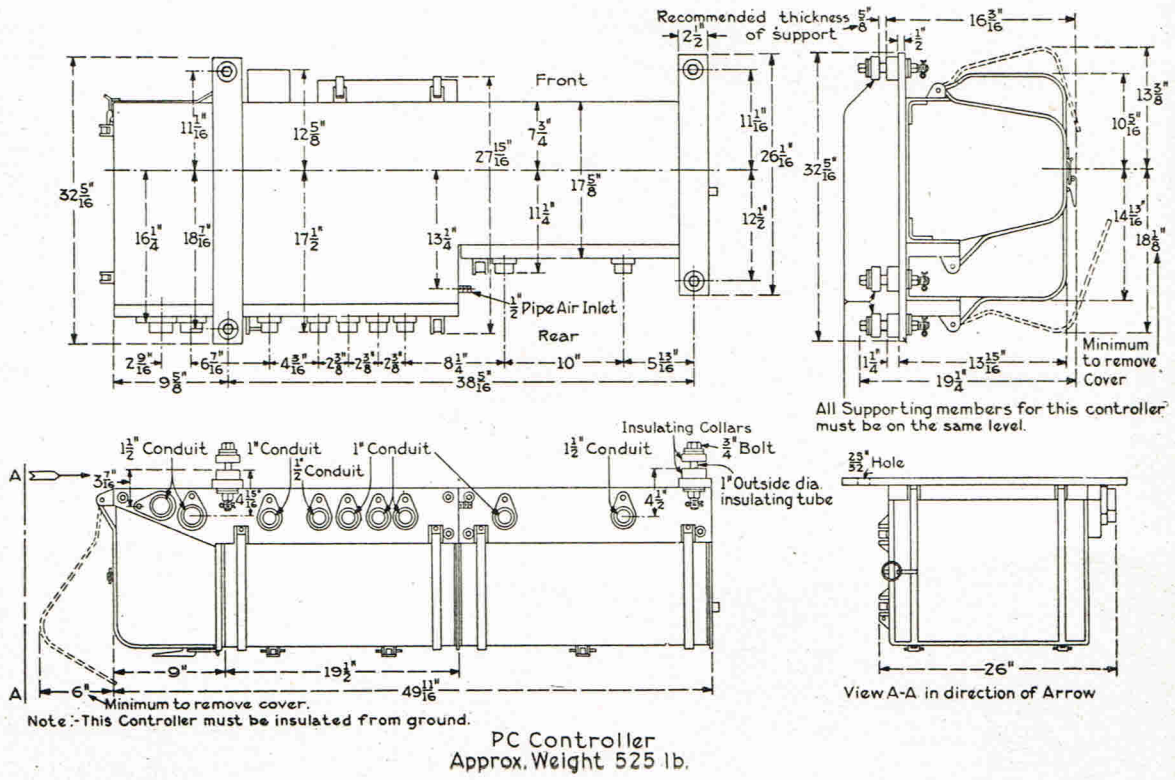

Fig. 5. Outline of Small PC Controller for Two or Four Motors, 600 Volts

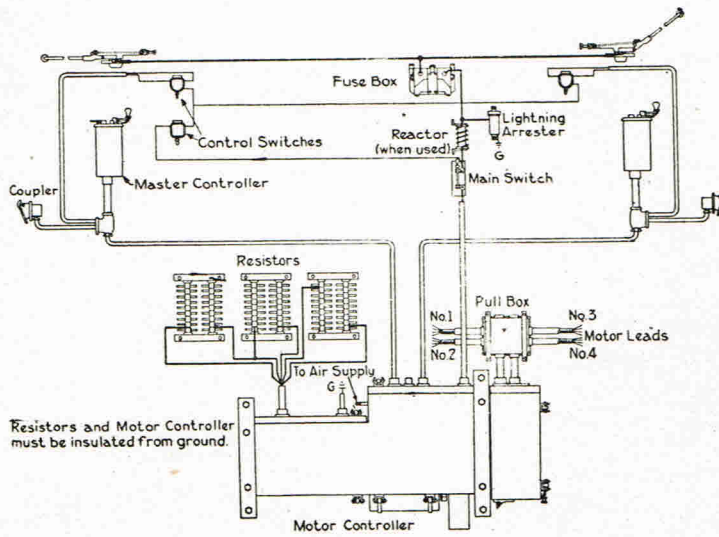

Fig. 6. Motor Controller Arrangement of 600-volt Car Equipment with Small Controller, PC-5

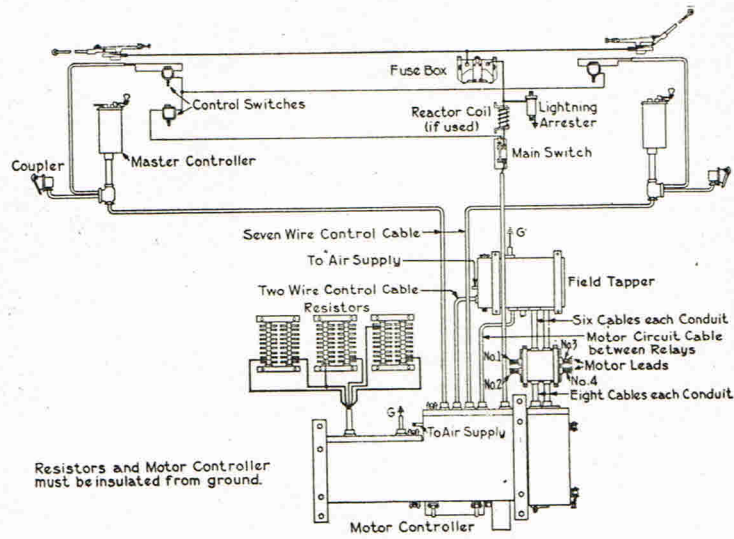

Fig. 7. Motor Controller Arrangement of Car Equipment with PC-5 Controller and Field Tapper

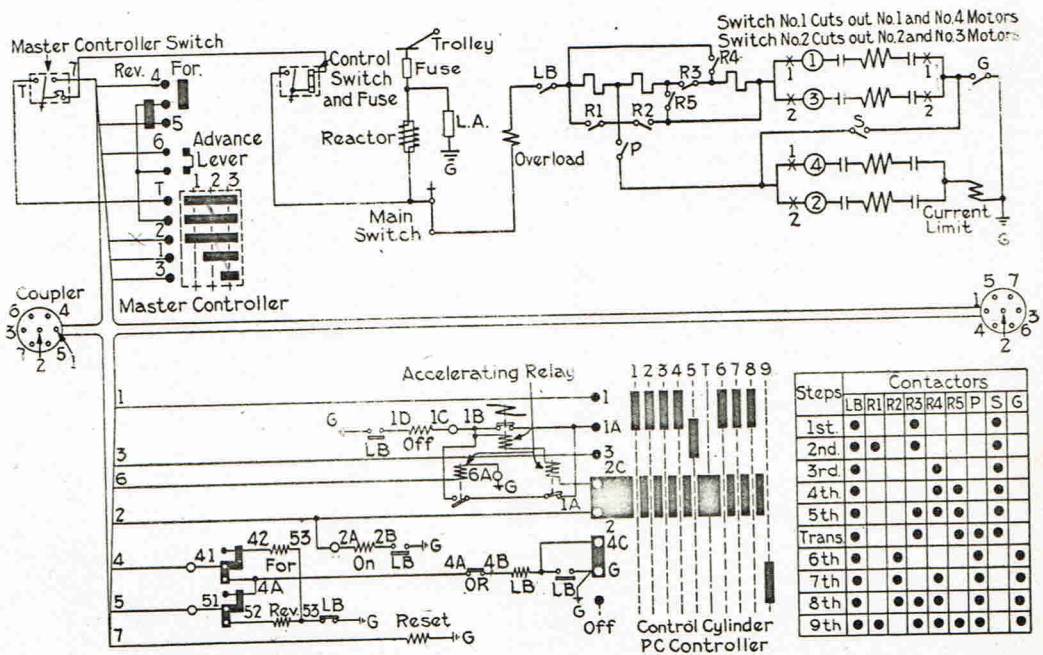
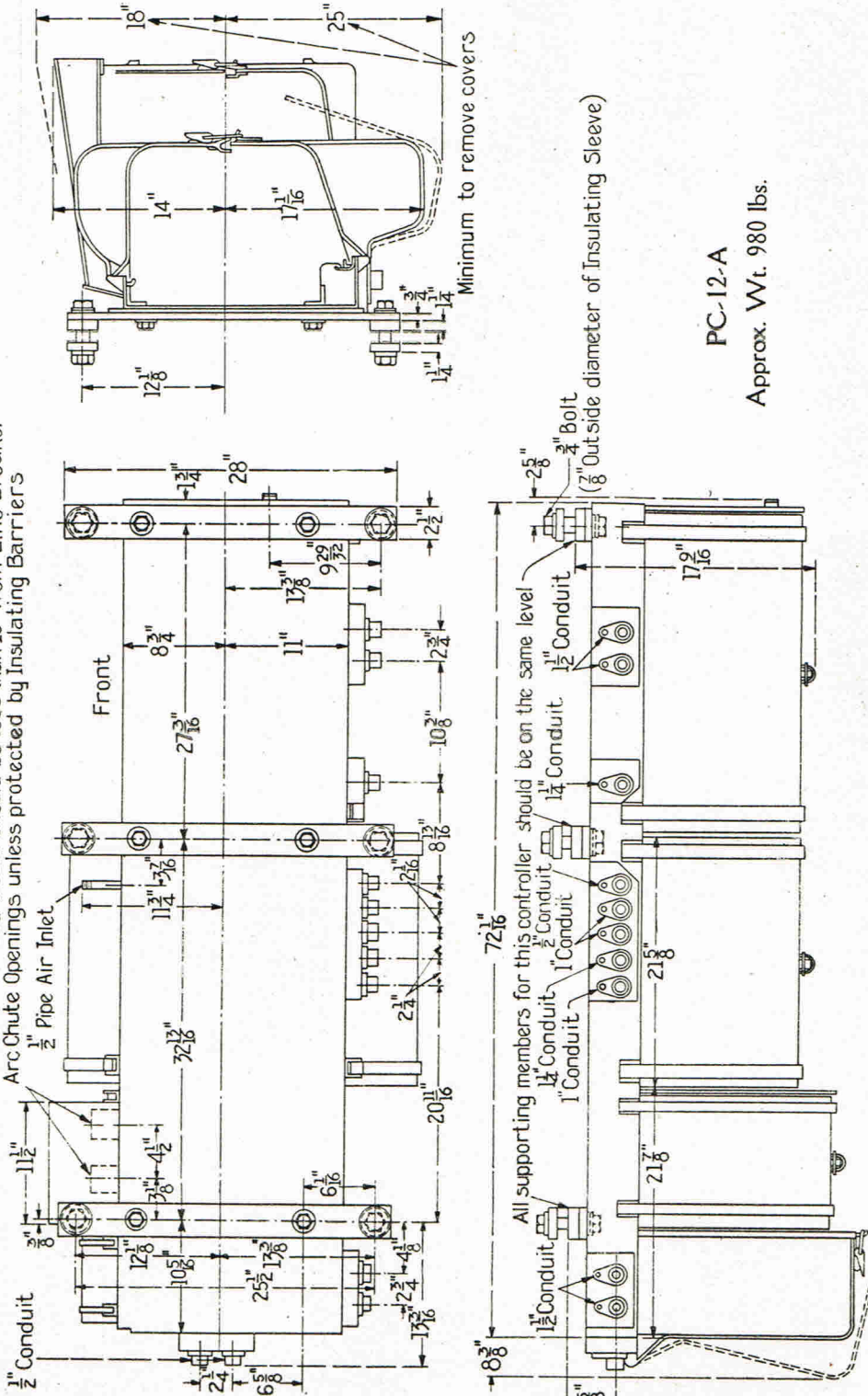

Fig. 8. Connections of PC-5 Controller and Four Motors

Note:-- The Frame of this Controller must be insulated from Ground and No Grounded Metal should be less than 10" from Line Breaker Arc Chute Openings unless protected by Insulating Barriers



PC-12-A

Approx. Wt. 980 lbs.

Fig. 9. Outline of Large PC Controller for Four-Motor 600-volt Equipments

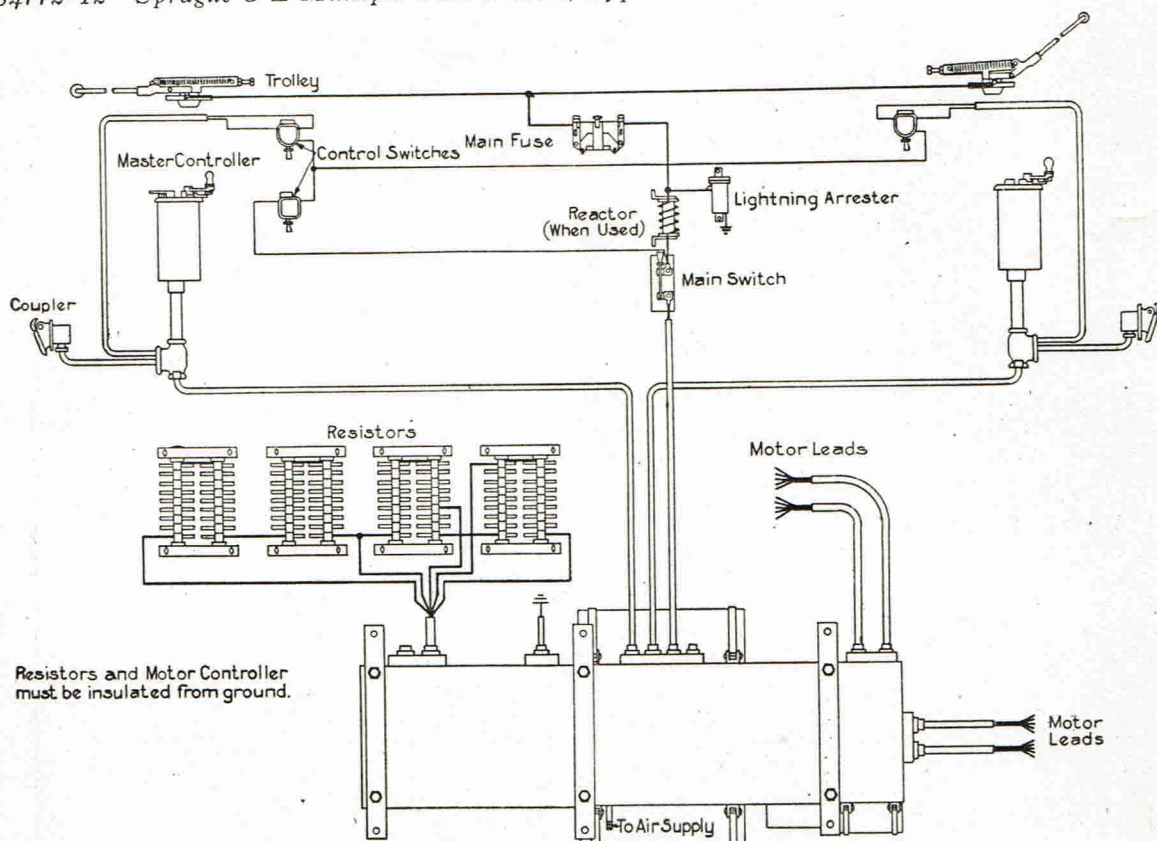

Fig. 12. Motor Controller Arrangement of 600-volt Car Equipment with PC-12 Controller

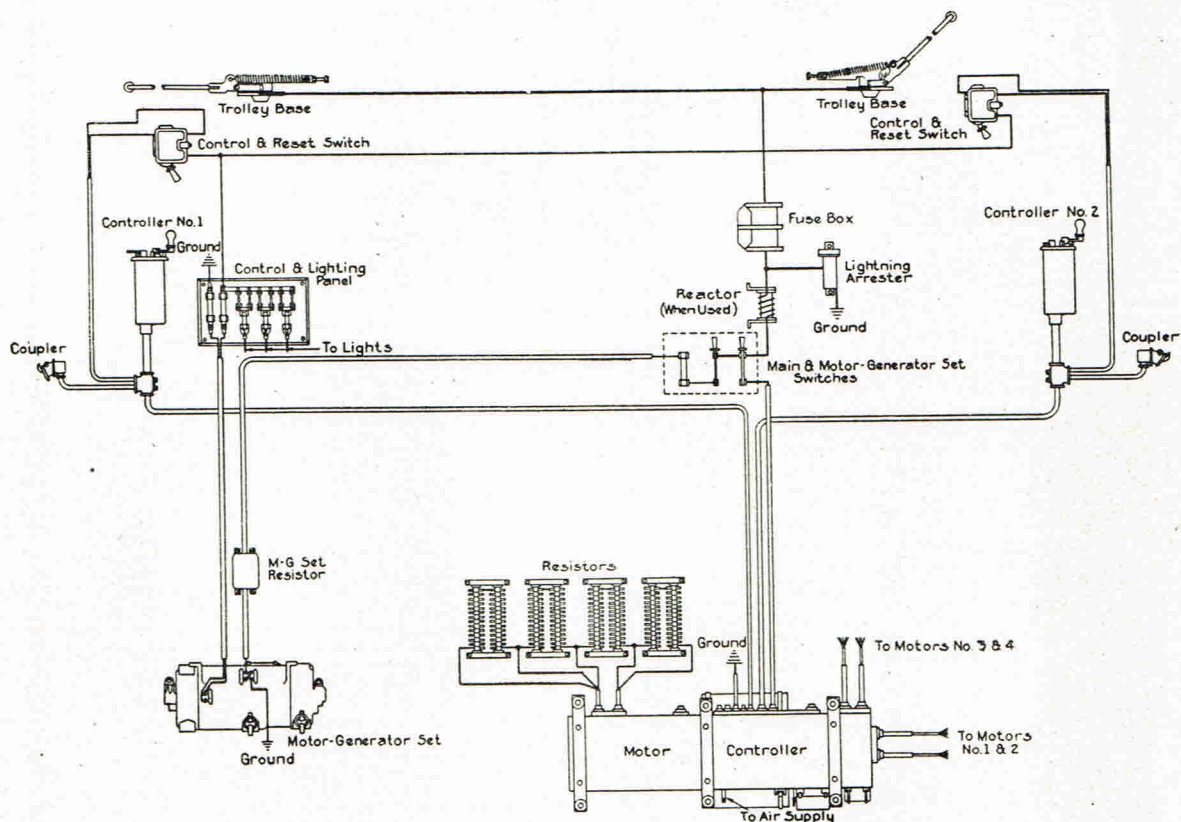

Fig. 13. Motor Controller Arrangement of Car Equipment with PC-101 Controller. For 1500-volt Operation Only

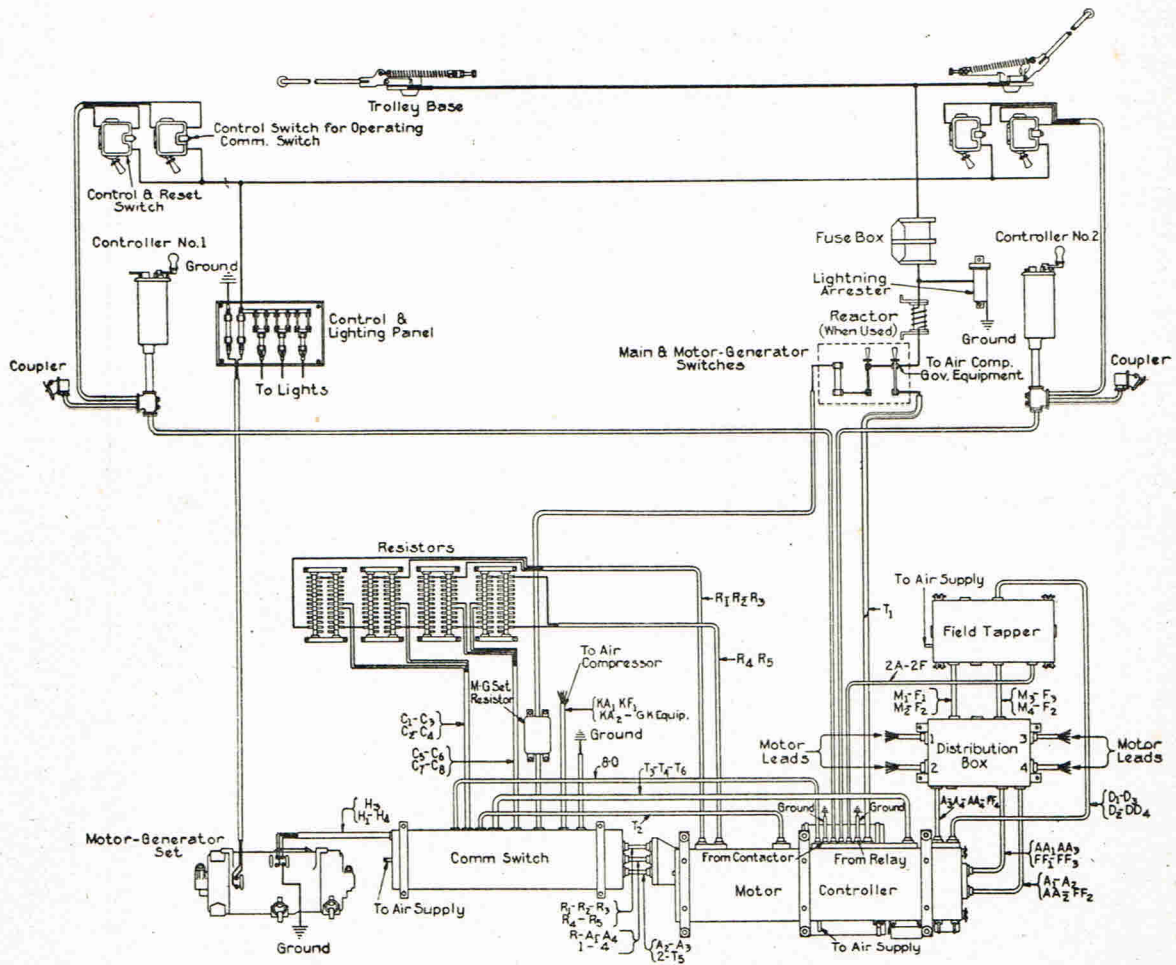

Fig. 14. Motor Controller Arrangement of Car Equipment with PC-101 Controller, Commutating Switch and Field Tapper. For Full Speed Operation on both 750 Volts and 1500 Volts

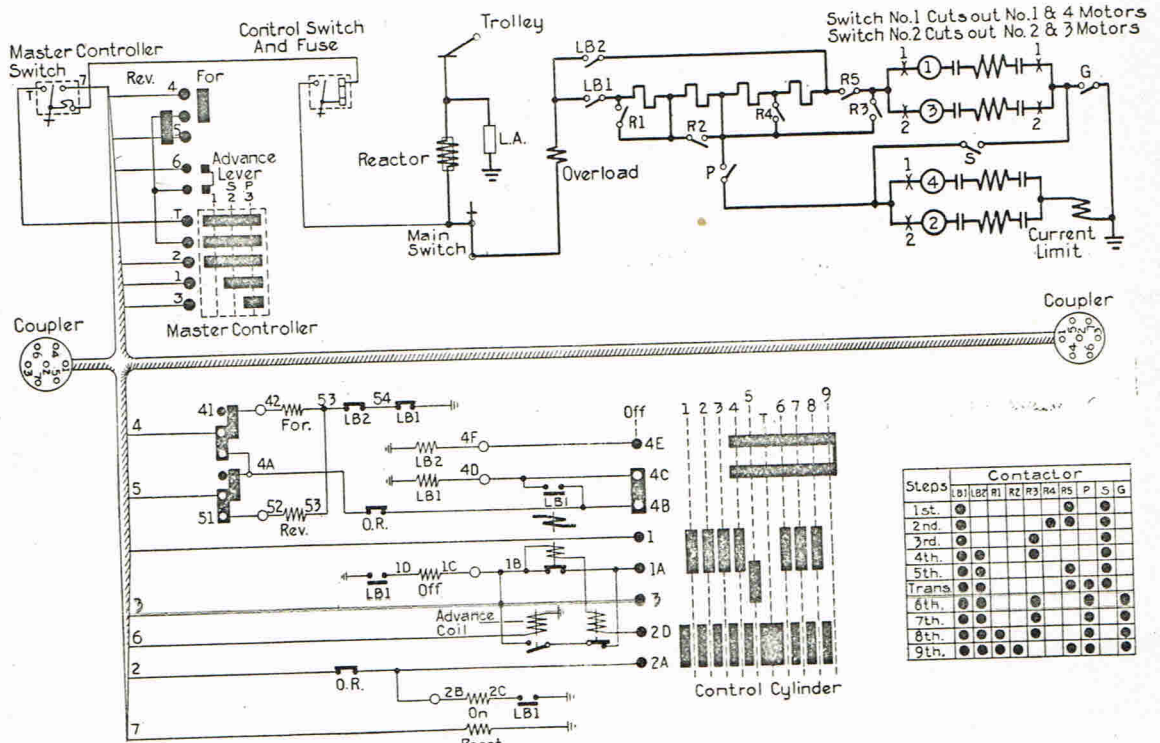

Fig. 15. Connections of PC-12 Controller and Four Motors

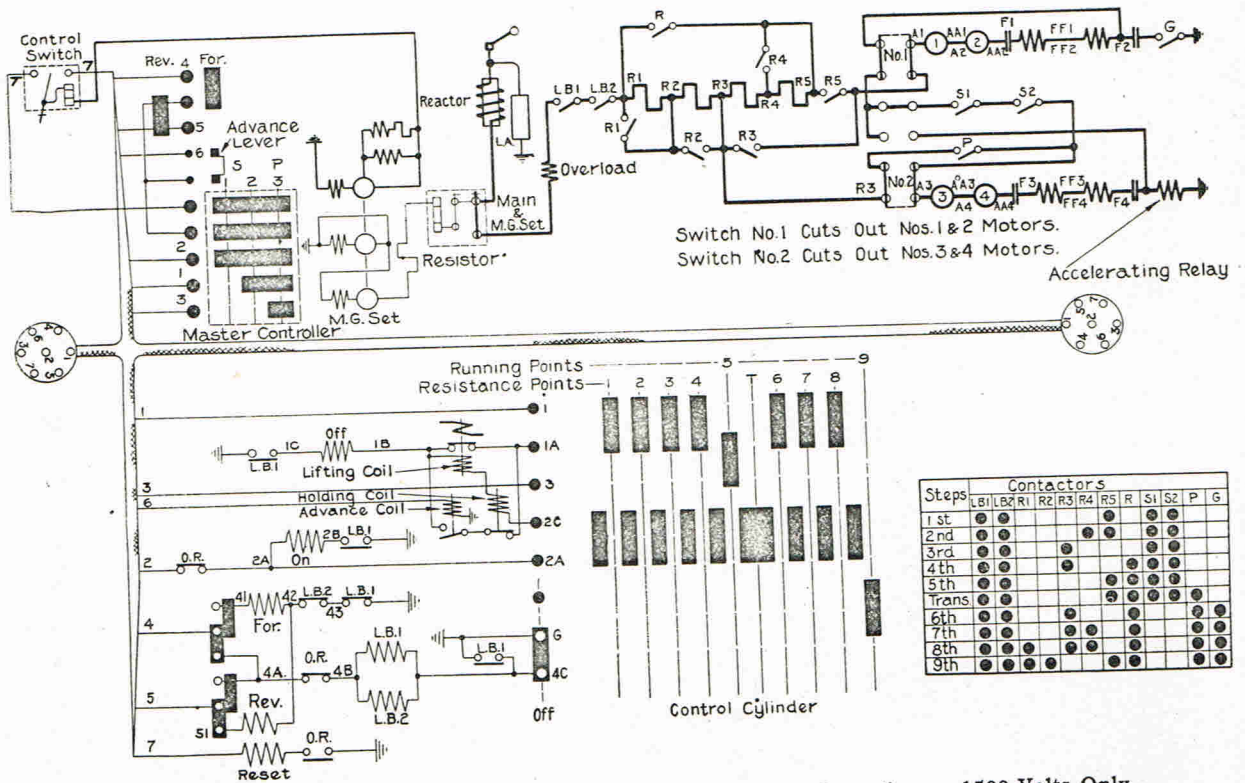
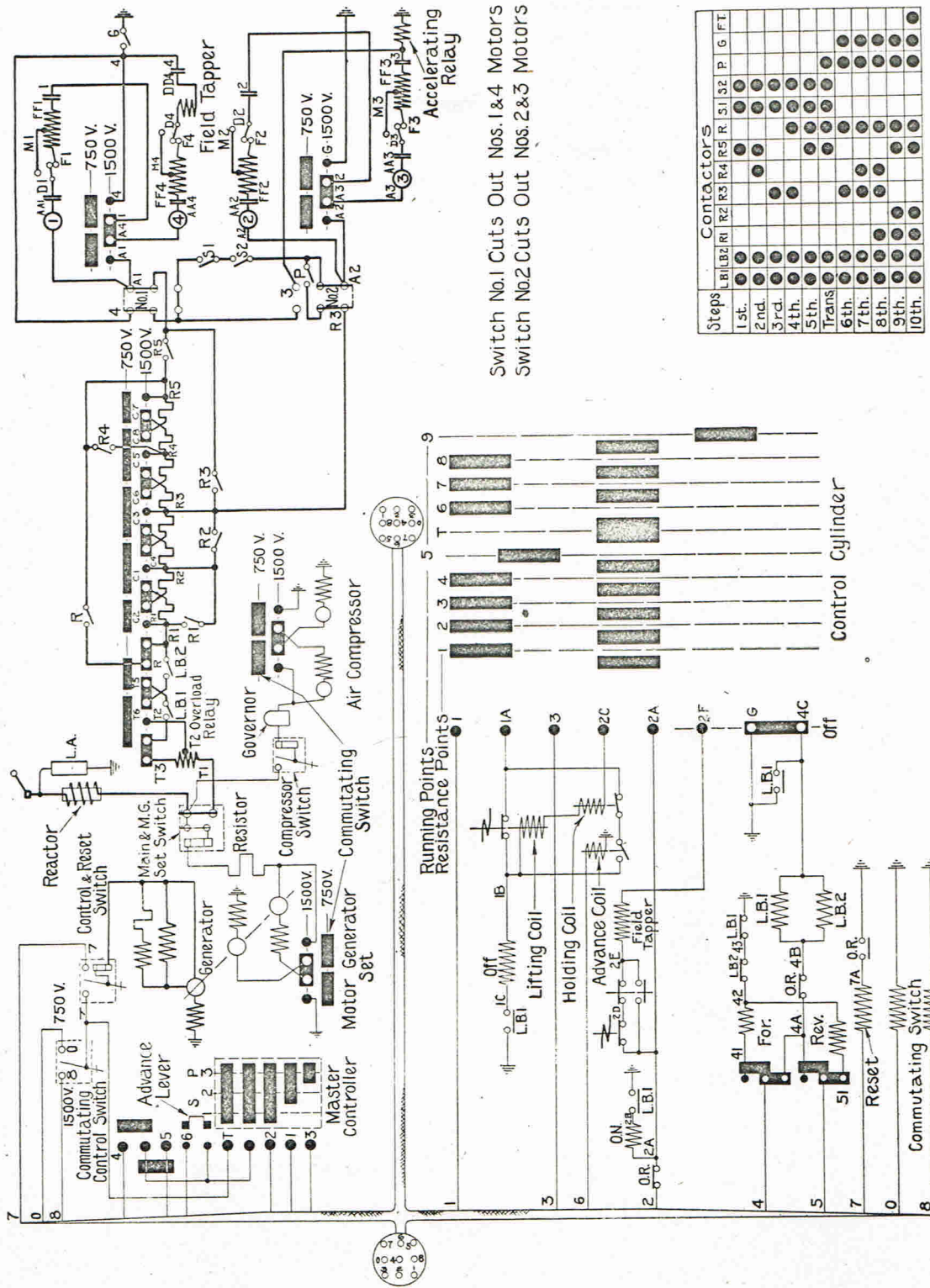

Fig. 16. Connections of PC-101 Controller and Four Motors. Operation on 1500 Volts Only



Switch No.1 Cuts Out Nos.1&4 Motors
 Switch No.2 Cuts Out Nos.2&3 Motors

Operation at Full Speed

Fig. 17. Connections of PC-101 Controller with Field Tapper and Four Motors.

on Both 750 Volts and 1500 Volts

For the PC controller, at least 15 ft. additional $\frac{1}{2}$ in. galvanized cooling pipe is recommended. This cooling pipe should be installed between the air brake reservoir and the control reservoir for the PC controller.

for 600-volt systems. When the voltage is 1200 or 1500, the distance should be six inches (6 in.). Where conduit is used, there should be at least three inches (3 in.) along the surface of the cable from the end of the conduit

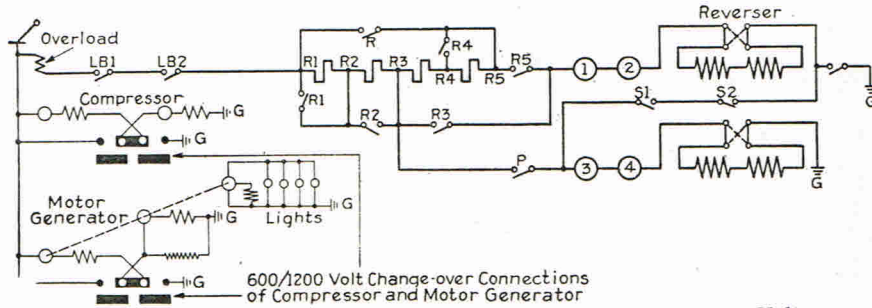

Fig. 18. Circuit Connections for Half Speed Operation on 600 Volts

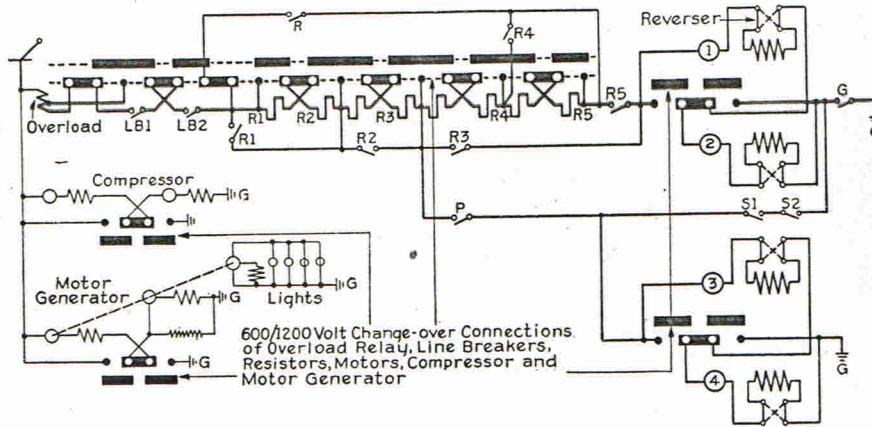

Fig. 19. Circuit Connections for Full Speed Operation on 600 Volts

The control reservoir should be located so that not over 15 ft. of pipe is needed to connect it to the PC controller. A shorter length is desirable. The piping diagram, Fig. 24, shows the general arrangement and connections of the air details.

The piping should be arranged to drain the moisture into reservoirs.

When installing the air piping for the control, care should be taken to remove all rust and scale. After the piping is installed, it should be pounded with a hammer and blown out before connecting to the strainer or PC controller.

MAIN FUSE BOX

Copper ribbon type fuse boxes are insulated from ground. Where wood is used for insulation, there should be at least three inches (3 in.) creepage distance between the fuse box supporting bracket and ground

to the fuse terminal on 600 volts, and on 1200 and 1500 volts six inches (6 in.).

CONTROL COUPLER SOCKETS AND PLUGS

After the coupler sockets are assembled and installed on the car, the back of the coupler socket should be filled with compound.

MOTOR RESISTORS

Porcelain bolt insulators are furnished for the supplemental insulation between the individual resistor frames and their hangers, as shown in Fig. 26. When installing, the bolt insulators should be arranged to prevent the short circuiting of the porcelain position by mud or grounded metal.

Grounded conduit should not be supported from the resistor frames.

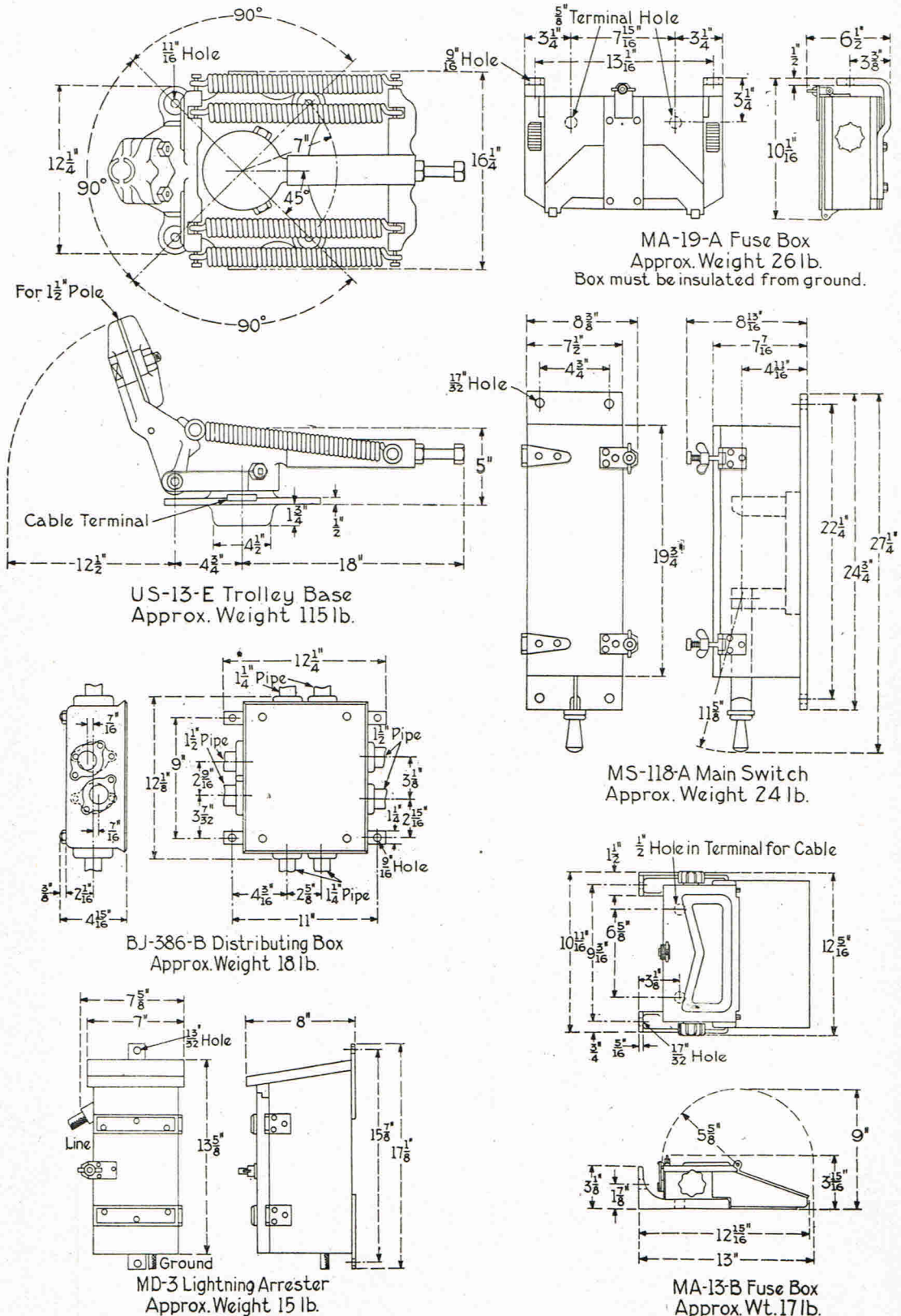

Fig. 20. Outlines of Electrical Apparatus Used with 600-volt PC Equipments

SEQUENCE OF PC CONTROLLERS

To reduce the burning of contactor arc chutes to a minimum, it is essential that there be a definite relation between the closing and opening of some of the contactors,

2 and 3, the tips of the R4 contactor should touch before the tips of the R1 and R3 open. Between points 5 and 6, the tips of P contactor should touch before the tips of R3, R4, R5 or S open and the tips of R5 contactor

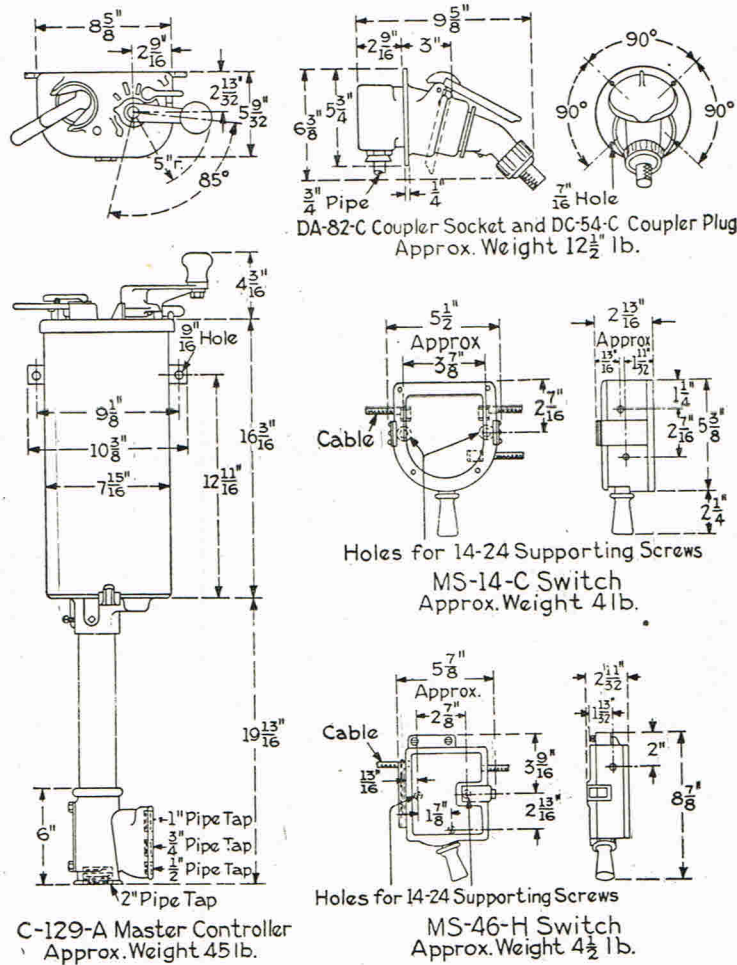

Fig. 21. Outlines of Electrical Apparatus Used with 600-volt PC Controllers

though adjustment to maintain this relation is not required for normal wear. This relation of contacts should be noted when a contactor is installed in the controller or the contactor pins and bearings are badly worn. To obtain the relation of contacts, turn the cam shaft with a wrench and see that the sequence as noted below is obtained.

SEQUENCE FOR PC-5 AND PC-6 CONTROLLERS

When the cam shafts of the PC-5 and PC-6 controllers are turned on between points

should be separated before the tips of R2 contactor touch. The tips of S contactor should be separated before the tips of G contactor touch.

SEQUENCE FOR PC-9 CONTROLLER

When the cam shaft of the PC-9 controller is turned on between points 5 and 6, the tips of P contactor should touch before the tips of contactors R1, R3 or S separate and the tips of R3 and S contactors should be open before the tips of the G contactor touch.

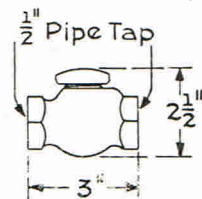
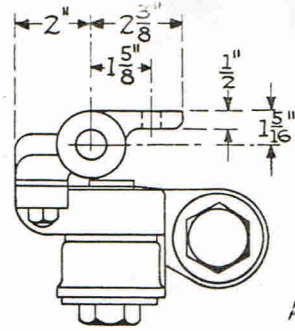
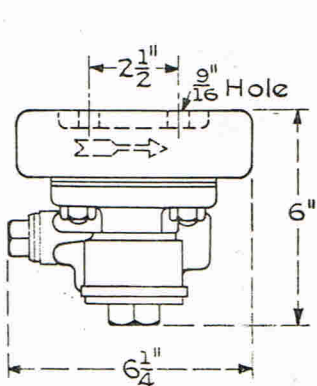

Check Valve
Approx. Weight 1 1/2 lb.

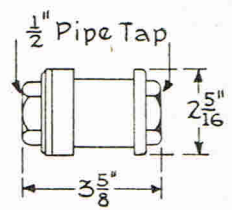

Strainer
Approx. Weight 1 1/2 lb.

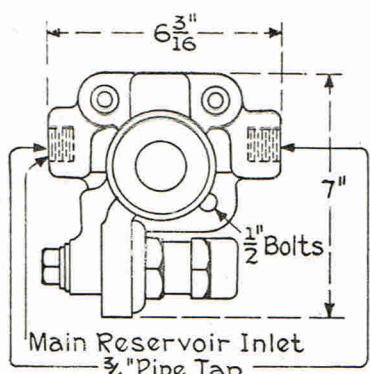

Main Reservoir Inlet
3/4" Pipe Tap
C-6 Feed Valve
Cat. 120457
Approx. Weight 15 lb.

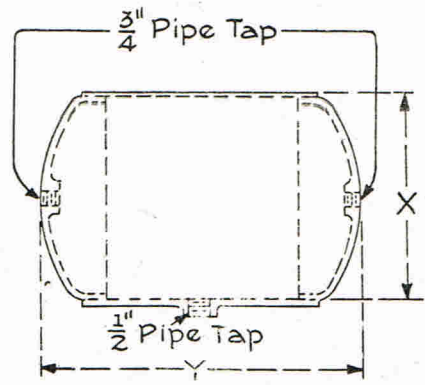

Reservoir

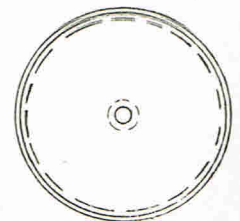

X	Y	Weight
10 in.	15 in.	15 lb.
12 in.	33 in.	40 lb.
16 in.	48 in.	97 lb.

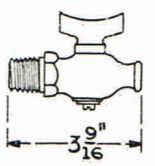

Drain Cock
Cat. 103079
Approx. Weight 1/2 lb.

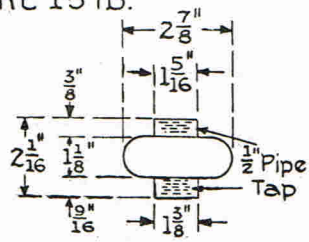

Pipe Insulation
Joint
Cat. 1609
Approx. Weight 1/2 lb.

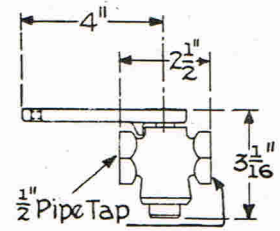

Cut Out Cock
Cat. 38565
Approx. Weight 1 1/2 lb.

Fig. 22. Air Auxiliaries Used with PC Controller

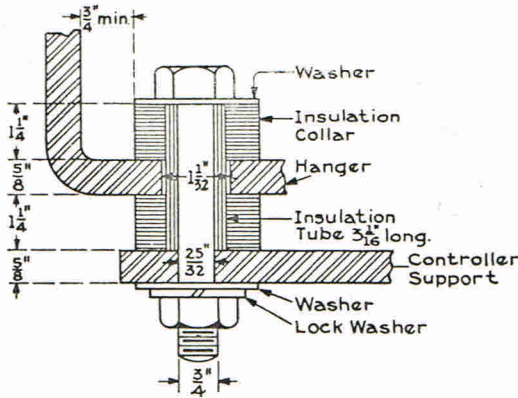

Fig. 23. Method of Insulating PC-5, PC-6, PC-9, PC-10 and PC-12 Controllers

SEQUENCE FOR PC-10 CONTROLLER

When the cam shaft of the PC-10 controller is turned on between points 5 and 6, the contact tips of the B contactor should touch before contact tips of the S, R12 and R22 contactors open. Between points 6 and 7, the tips of the P contactor should touch before the tips of B contactor open and the tips of the B contactor should be out of contact when the tips of the G contactor touch.

SEQUENCE FOR PC-12 CONTROLLER

When the cam shaft of the PC-12 controller is turned on between points 2 and 3, the tips of the R3 contactor should touch before the contact tips of contactors R4 and R5 separate. Between points 4 and 5, also 8 and 9, the tips of the R5 contactor should touch before the tips of R3 separate. Between points 5 and 6, the tips of P contactor should touch before tips of S or R5 separate and the tips of the S contactor should be open before the tips of the G contactor touch.

SEQUENCE FOR PC-101 CONTROLLER

When the cam shaft of the PC-101 controller is turned on between points 2 and 3, the tips of the R3 contactor should touch before the tips of either the R4 or R5 contactors separate. Between points 5 and 6, the tips of the P contactor should touch before the tips of R5, S1, and S2 contactors separate and the tips of contactors R5 and S2 should be separated when the tips of contactors R3 and G touch. Between points 8 and 9, the tips of R5 contactor should touch before the tips of R3 contactor separate.

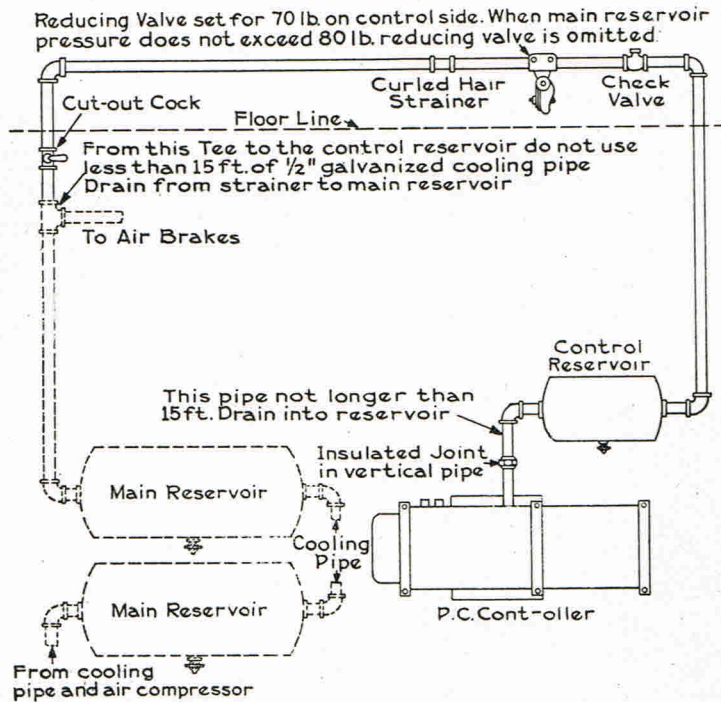

Fig. 24. Piping Connections of PC Control

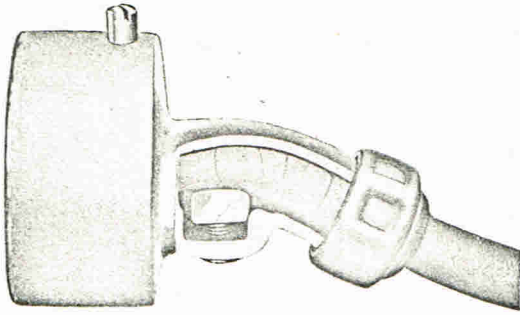

Fig. 25. Type DC Coupler Plug Showing Method of Clamping the Cable

PC-5, PC-6 AND PC-7 CONTROLLERS

CONTACTOR UNITS, CONTROL DRUM AND CAM SHAFT

The removal and replacement of these parts are exactly the same as for the PC-10 and PC-12 controllers. The description will be found on a following page.

LINE BREAKER

The ARC CHUTE is removed by taking out two cap screws. These cap screws are accessible from the bottom of the controller and are located in the arc chute pole pieces,

on the outside of the arc chute, adjacent to the contact tips.

To remove the line breaker piston packing, it is necessary first to take off the arc chute, then take out one of the transite barriers. This allows the pins through the operating and contact levers and the levers to be taken out. The cylinder head may now be taken off and the piston packing removed.

REVERSER

The reverse cylinder may be removed by disconnecting and removing the cutout switch and end bearing of the reverser. Then the reverse cylinder may be taken out through the door that covers the cutout switch.

PC-10 AND PC-12 CONTROLLERS

CONTACTOR UNITS

When a complete contactor is put in the PC-10 or PC-12 controller, its position may be located from its cam roller. Slotted holes in the contactor support provide means of adjustments. As all of the cam rollers are in line, a straight edge held against those in position will locate the one being put in.

The arc chute should be closed before the cap screws fastening the contactor in place are finally tightened, in order that the contactor may shift sideways until it takes its correct position.

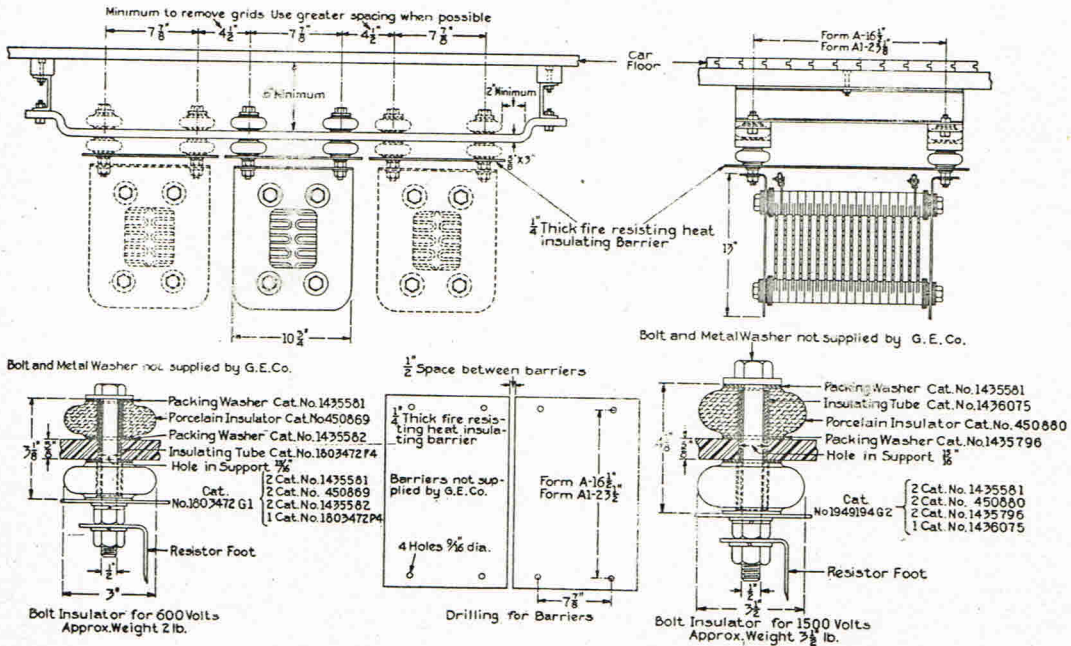

Fig. 26. Method of Supporting Type RG Resistors Using Porcelain Bolt Insulators for 600- and 1500-volt Work

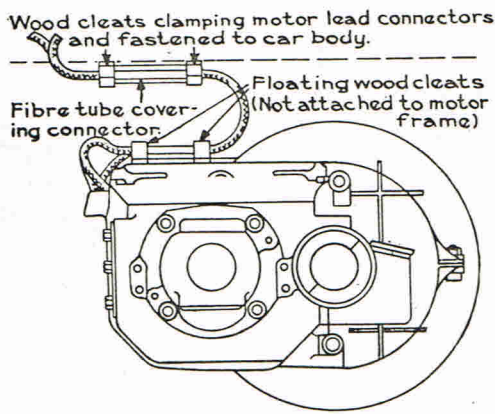

Fig. 27. Diagram of Railway Motor Connections to Car Body for Use with Type PC Control

CONTROL DRUM

In order to remove the control drum, take out the cap screws holding the bearing at the line breaker end of the cylinder. Then slip the bearing off the shaft and the drum can be easily disengaged from the clutch and removed.

It is possible to put the control drum in place 180 deg. from its correct position, and to prevent this, the two parts of the clutch, between the drum and the cam shaft, are marked.

CAM SHAFT AND PINION

To remove the cam shaft, first take out the control drum, then take off the steel strap used as a stop for the covers. The cap bolts holding the cam shaft bearings can now be taken out and the cam shaft removed.

In order that the cam shaft and pinion may be correctly assembled in the rack, the best method is to mark the pinion and rack before taking these parts out. In case this is not done, the rack and pistons should be pushed toward the "on" magnet valve as far as they will go. The cam shaft and pinion are then put in place, so that none of the cams touch the cam rollers on the contactors.

LINE BREAKER

The **pneumatic portion** of the line breaker is removed by disconnecting the control leads on the magnet valves, breaking the air connection at the pipe union and removing the four cap screws holding these parts to the controller frame. The air cylinders and magnet valves may then be removed toward the back of the controller until the yoke is disconnected from the pin through the contact arm. Fig. 36 shows this yoke and pin.

The **arc chute** is removed by taking out two cap screws. These cap screws are accessible from the bottom of the controller and are located in the arc chute pole pieces, on the outside of the arc chute, adjacent to the contact tips.

PC-101 CONTROLLER—1500 VOLTS

The removal and replacement of the contactor units, reverser, control drum, cam shaft and main engine parts are practically the same for the PC-10 and PC-12 controllers.

The **arc chute** is removed by taking out screws and parts as indicated by numbers 1, 2, and 3, in Fig. 28.

MAIN ENGINE

(PC-10, PC-12 and PC-101 Controllers)

REMOVING PISTON SPRING

In order to take the mechanism apart, refer to Fig. 29.

1. Remove cylinder head on "off" magnet end of main cylinder and revolve cam shaft

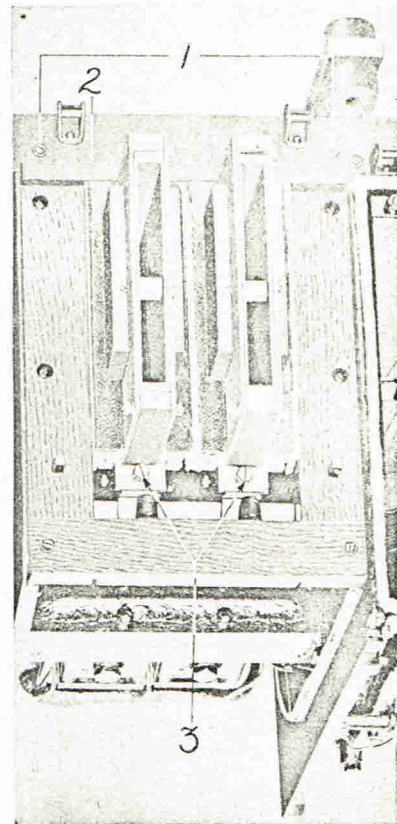

Fig. 28. Type PC-101 Controller, Parts to be Detached to Remove Arc Chutes of Line Breaker

by means of wrench, Cat. No. 176776, until piston head (1) is near enough to the outer end of the cylinder to be accessible.

2. Remove cotter pin (2), nut (3), washers (4), and follower (5), expansion spring (6) and leather packing cups (7).

3. Remove lock screw (8).

4. Remove stud cap (9) by means of a pin wrench, Cat. No. 176775.

to see that rack (12) is guided into the hole in piston head (1).

Put piston guide (13) and lock washer (14) in place and screw cap-screw (10) down firmly on the washer by means of screw-driver, Cat. No. 189905.

Remove wrench from cam shaft, thus allowing spring (11) to drive rack (12) out until piston guide (13) bears against the

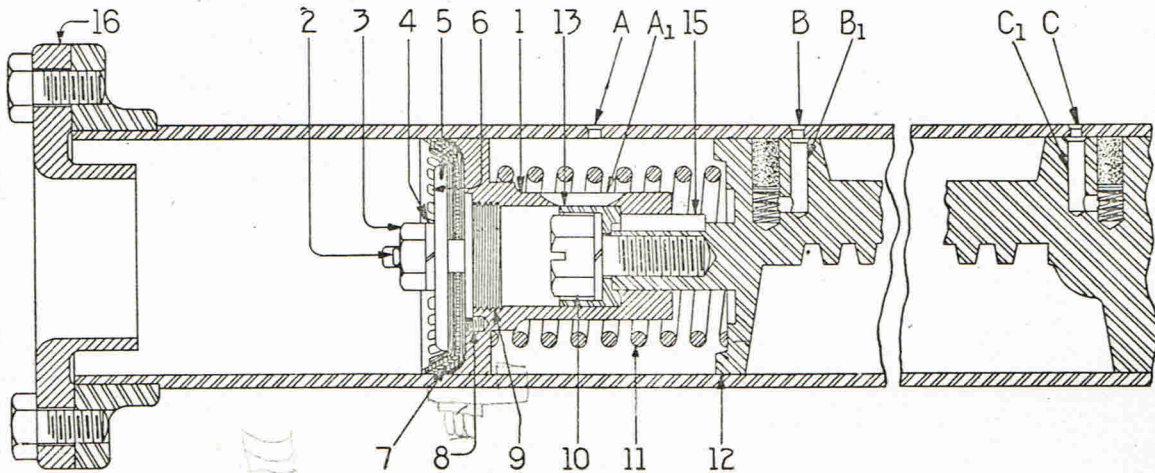

Fig. 29. Section Through Main Cylinder Showing Piston for Types PC-10, PC-12 and PC-101 Controllers

5. Fasten ring (16), Cat. No. 176773, to cylinder flange, in place of cylinder head and revolve cam shaft until piston head (1) is forced against it with considerable pressure.

6. Remove cap screw (10) by means of a screw-driver, Cat. No. 189905, and then turn cam shaft in the opposite direction until the pressure on ring (16) is relieved.

7. Remove ring (16). Piston head (1) can now be slipped out, giving access to spring (11).

REPLACING PISTON SPRING

With the rack (12) in place, turn the cam shaft until the end of the rack is accessible through the opening in the end of the cylinder.

Insert spring (11) and piston head (1), taking care that the spring (11) is properly placed over the shoulder on rack (12) and that the key (15) in rack lines up with the keyway in piston head (1).

Fasten ring (16) to the cylinder flange and turn the cam shaft until spring (11) is compressed. While doing this, it will be necessary

shoulder in the bore of piston head (1). See that the parts which slide are perfectly free and that the spring forces rack (12) back without hesitation.

Remove ring (16).

Oil the bore of the piston head (1) in order that piston guide (13) will slide easily.

Put stud cap (9) in place, by means of pin wrench, Cat. No. 176775, and lock it in by means of lock screw (8).

Replace leather cups (7), expansion ring (6), follower (5) and washer (4), nut (3) and cotter pin (2).

Replace cylinder head.

When the assembly is completed, turn the cam shaft to the "off" position, fill the air tanks, admit air to the "on" cylinder by pressing down the operating pin of the "on" magnet valve. The cam shaft should turn from the "off" to the first position, which may be noted by the contactors closed. When the air is released from the "on" cylinder, the cam shaft should turn to the "off" position. If this does not occur, or the operation is sluggish, there is some fault in the assembly of the piston spring.

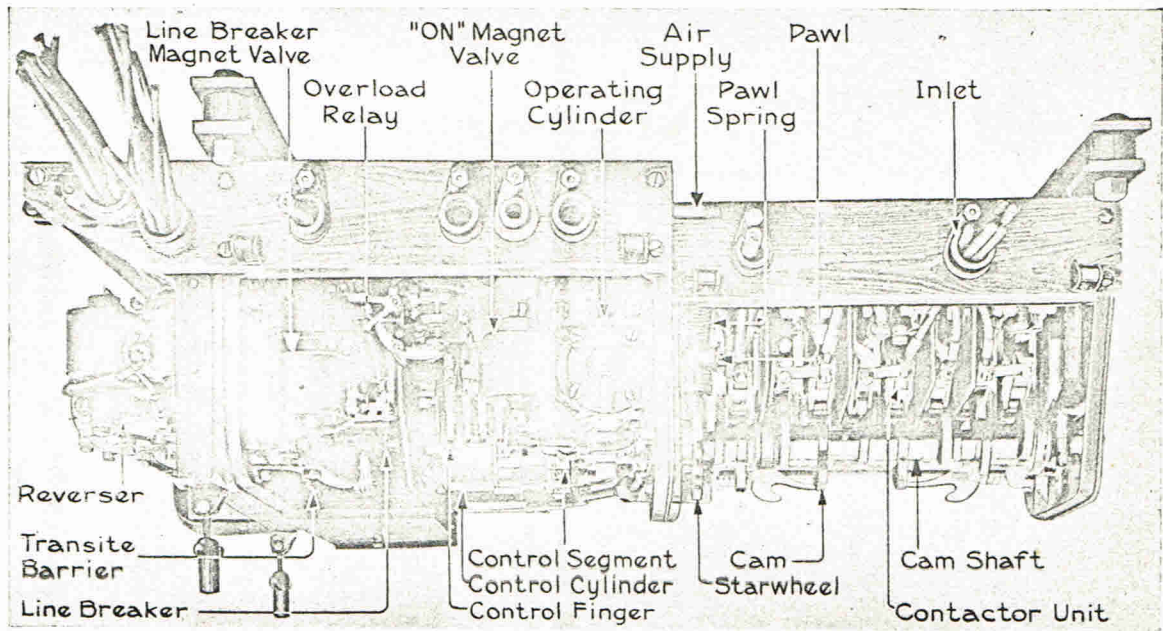

Fig. 30. PC-5 Controller

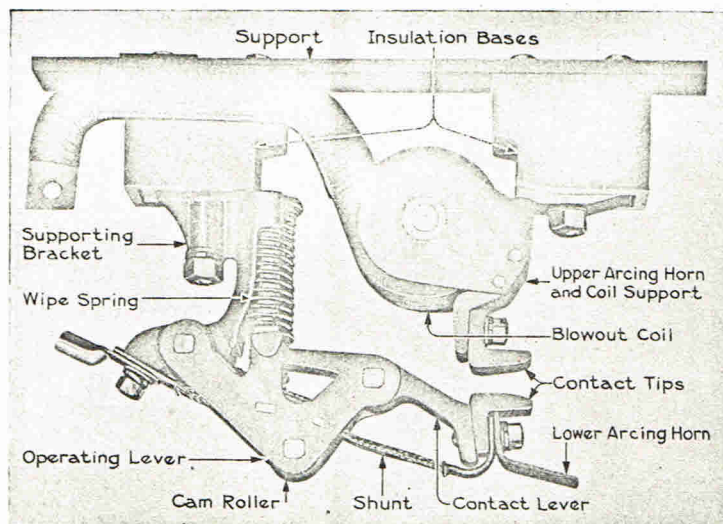

Fig. 31. Contactor Unit for Types PC-5, PC-6 and PC-9 Controllers

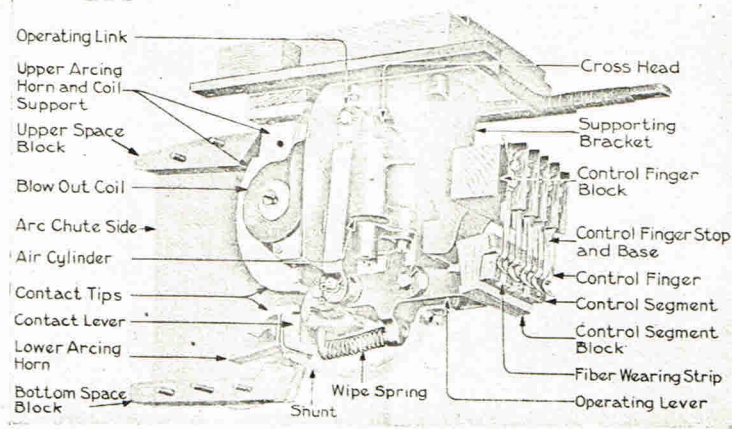

Fig. 32. Line Breaker Unit for Types PC-5, PC-6 and PC-9 Controllers

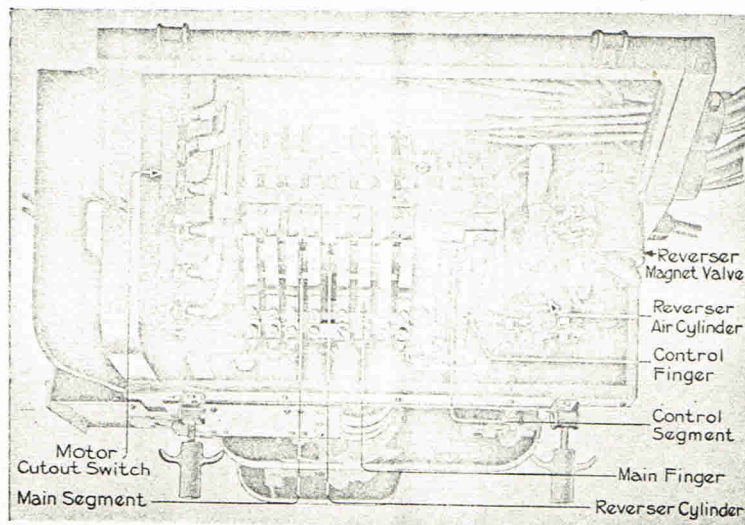

Fig. 33. PC-5 Controller (Reverser End)

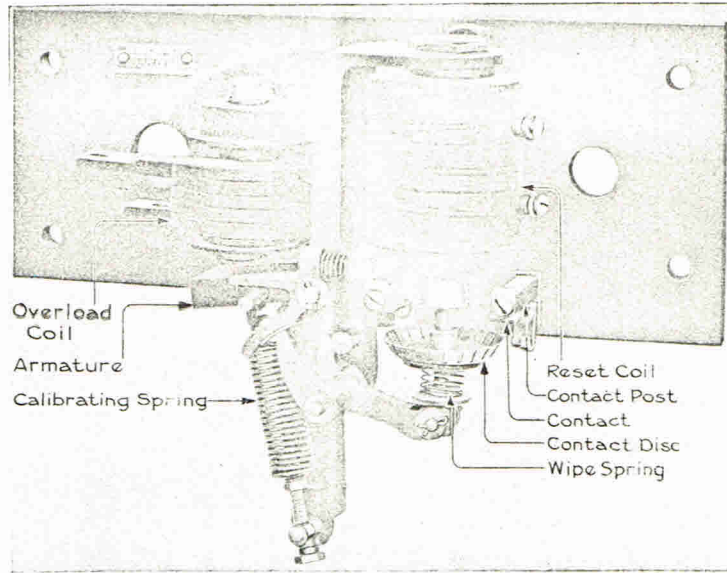

Fig. 34. Overload Relay for Types PC-5, PC-6 and PC-9 Controllers

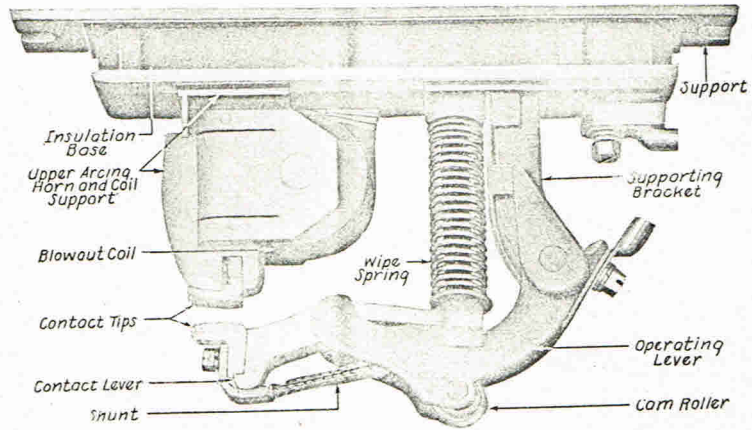

Fig. 35. Contactor Unit for Types PC-10 and PC-12 Controllers

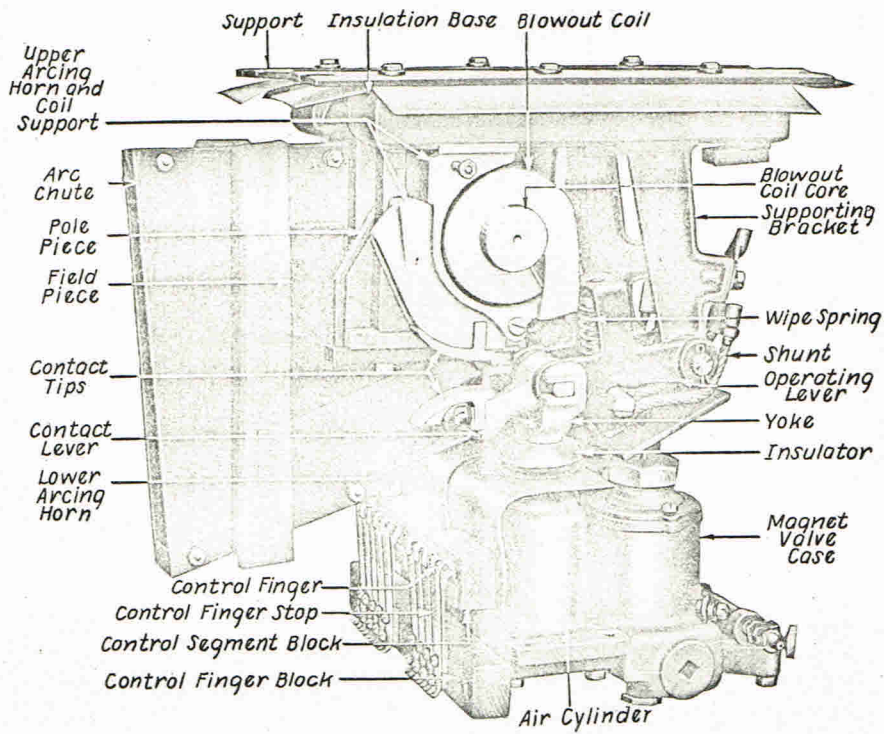

Fig. 36. Line Breaker Unit for Types PC-10 and PC-12 Controllers

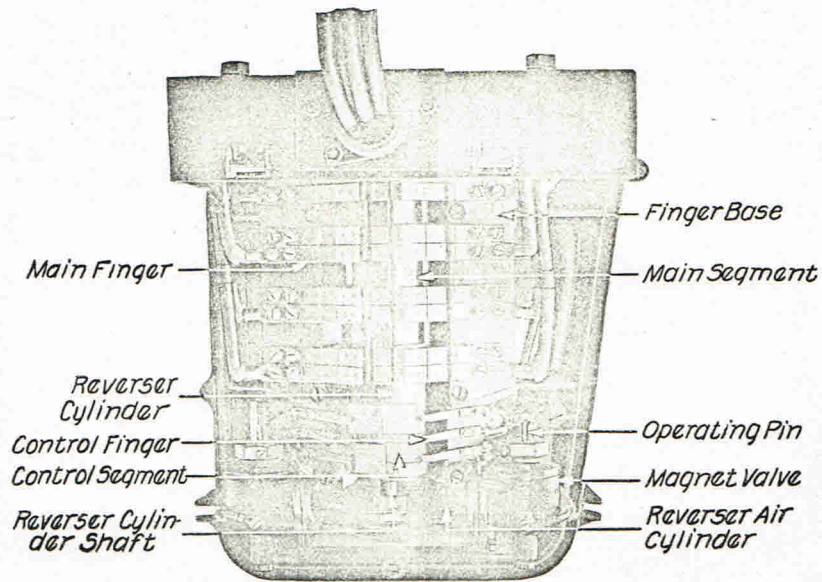

Fig. 37. Reverser for PC-10 Controller

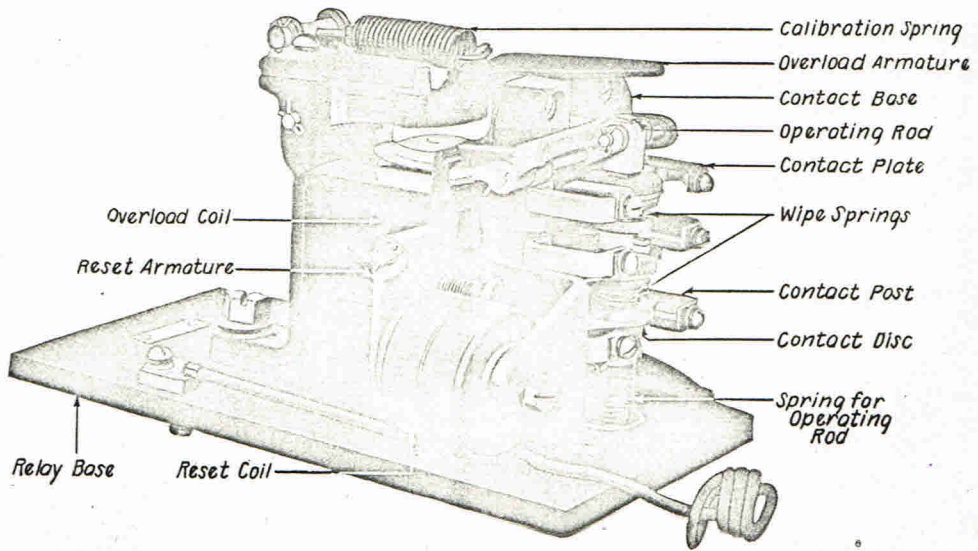

Fig. 38. Overload Relay for Types PC-10 and PC-12 Controllers

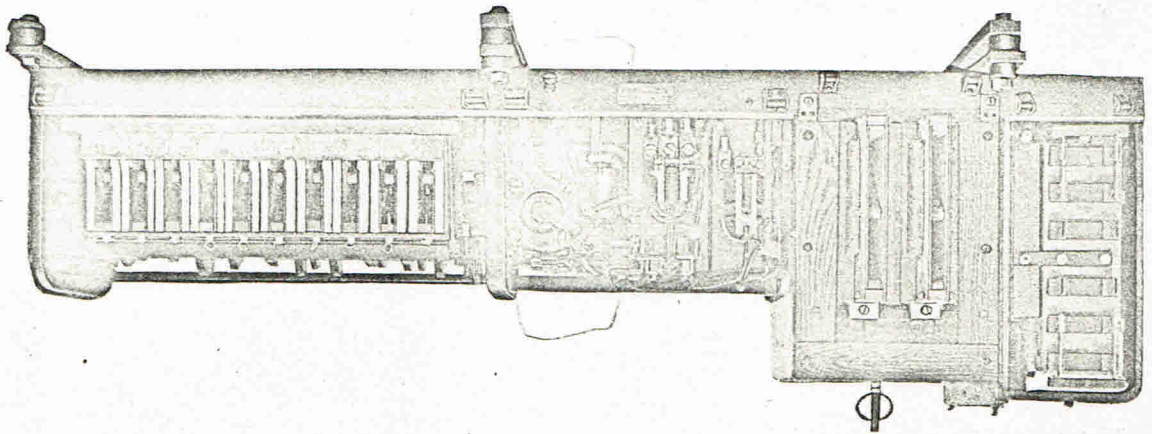

Fig. 39. Type PC-101 Form A Motor Controller

ACCELERATING RELAY

The accompanying diagram, Fig. 40, shows the simplified control connections of the DB-808 accelerating relay with by-pass feature.

coils. The latter aids the series coil in attracting its armature. This circuit, indicated by the full light line, insures that the PC controller will advance to the next point even though the rise of current in the series coil between points causes contacts "A" to open.

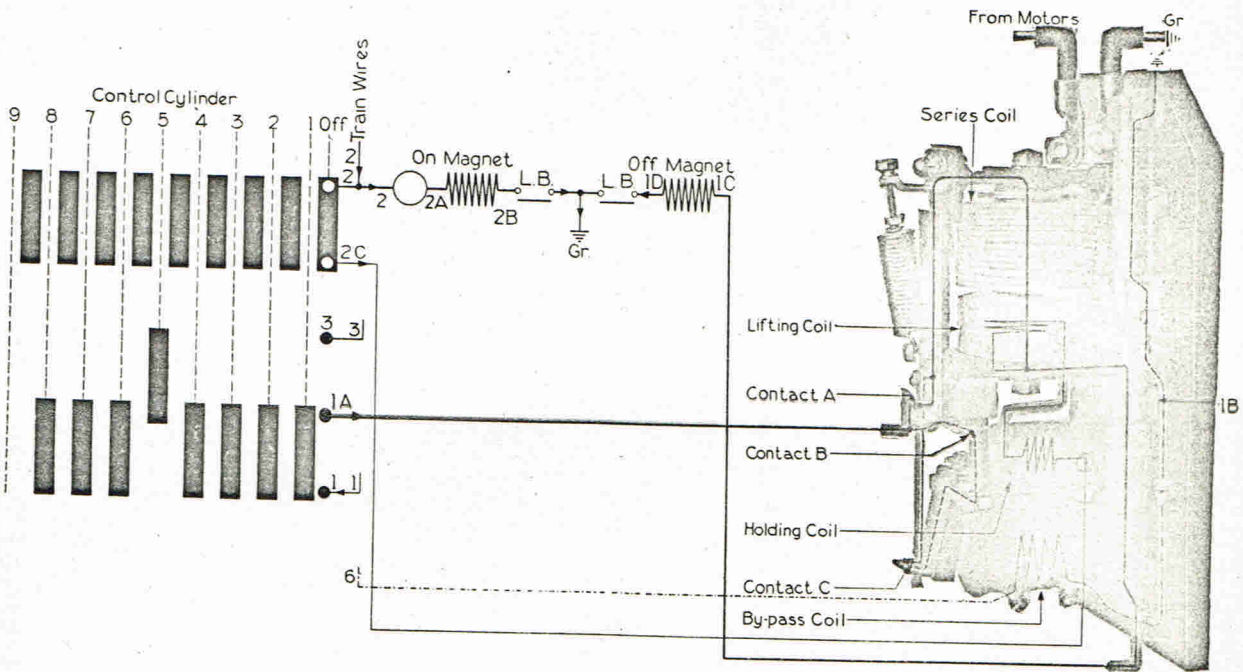

Fig. 40. Type DB-808 Relay (Control Connections)

NORMAL OPERATION

Assume the master controller is advanced to the third or full parallel position, connecting wires No. 1, 2, 3, and 4 to their source of energy. This causes the line breaker in the PC controller to close which closes the interlocks "LB" in the "on" and "off" magnet valve circuit, and the PC controller is advanced to the first position. If the current through the motors and the series coil of the relay exceeds a predetermined value causing the series coil armature to be attracted holding contacts "A" open, then the "off" magnet valve will not be energized until current through the motors decreases to such a value that this relay armature is released allowing contact "A" to close. The circuit will then be through wires 1, 1A, 1B, 1C, as indicated by the full heavy line, causing current to flow through the "off" magnet valve coil, advancing the PC controller toward the second point. As wire 1A leaves the segment, wire 2C makes contact with its segment energizing the holding and lifting

This sequence of operation continues until the full series, or 5th point on the above diagram, is reached when the 1A wire is energized by the segment making contact with the No. 3 wire. This allows the PC controller to advance to the parallel position after the current through the motors drops to the proper value. The sequence of operation then continues as in the series positions.

EMERGENCY OPERATION

If the PC controller is on some point where the current through the series coil is too great to release its armature although not enough to start the car an additional point on the PC controller can be obtained by energizing wire No. 6 with the advance lever on the master controller, thus energizing the by-pass coil, attracting its armature and closing contact "C." The current will then flow through wire 1A, through contacts B, C, etc., as indicated by the heavy dotted line, thereby by-passing contacts "A," thus energizing the "off" magnet and advancing the PC controller even though these contacts "A" remain open.

The magnetic circuits of the by-pass and holding coils are so arranged that with the by-pass coil energized the flux leakage from the coil will hold the contacts "B" open after they have been opened by the holding coil being energized. By energizing wire No. 6 the PC controller can be advanced but a single point as wire 2C is energized during the advance, between points, causing the holding coil to attract its armature opening contacts "B" breaking the circuit through the "off" magnet coil. This causes the PC controller to pause on each point until the advance lever is again released allowing contacts "B" to close preparing the circuit for the next bypass around contacts "A."

When the relay is used on equipments the control of which operates from a low voltage source resistor tubes are omitted.

USE OF THE BY-PASS FEATURE FOR TESTING THE CONTROL

By inserting a piece of thin cardboard or other insulation between contacts "A" the advance lever can also be used in testing the control, when there is no current in the series coil, to see that it advances properly from step to step. When the PC controller is on any point except the last and the by-pass coil is energized contacts "C" are closed completing the circuit through the 1 and 1A wire and contacts "B" and "C" through the "off" magnet coil, as indicated by the heavy dotted line, causing the PC controller to start to advance to the next step. When advancing between points wire 2C is energized and the circuit closed through the "off" magnet coils which insure that the PC controller advances one step. The holding coil being energized attracts its armature causing contacts "B" to open, thus making it necessary to release the advance lever, opening the circuit in the by-pass coil, before contacts "B" will again close.

MAINTENANCE

The work of maintaining equipments and the frequency of inspections necessary, depend greatly on local conditions, which are the real determining factors.

As a general rule, city equipments should be inspected every 500 to 1000 miles and interurban equipments from 1000 to 2000 miles.

A list of the points to be noted when inspecting a controller is pasted in the back cover of the main contactor compartment. A more detailed description follows of the work to be done.

OPERATING TEST

At each inspection the main switch should be opened and with an air pressure of not

less than 60 lb., the PC controller operated from each master controller, with the reverse handle thrown in the forward and reverse positions. This test immediately tells whether the pieces of apparatus are working.

The master controller should be held on points 1 and 2 long enough to insure that the PC controller definitely stops on the corresponding positions. The controller should be advanced a step at a time, the same as during acceleration, by using the "advance" lever on the master controller, or, by repeating the current limit relay by hand. The overload relay should be tripped by hand and reset from the cab.

If when turning to full series or full parallel, the shaft vibrates when stopping, check the following:

1. Be sure that the shaft is not turning on too fast.
2. If equipped with an accelerating valve, be sure that the stem is not travelling too far and that it is working freely and not sticking open. The stem in this valve should travel approximately $\frac{1}{4}$ in. on the first point. If a new stem is installed it should be cut off to give this travel.
3. See that the small hole in the reducing bushing in the pipe line next to the on valve is open.

INSPECTION

At each inspection the master controller, master control switches, main switch, fuse box and PC controller should be opened, examined, cleaned, adjusted or repaired if needed.

The following points should be noted:

MASTER CONTROLLER

- (a) Inspect for weak fingers, imperfect contact and loose connections.
- (b) Clean contacts when dirty and apply a small quantity of thin lubricating oil to the contacts with a piece of cheese cloth.

CONTROL SWITCHES

- (a) Inspect for poor contact.
- (b) Clean and lubricate when needed.

MAIN SWITCH AND FUSE BOX

- (a) Inspect for loose terminals and poor contact.

PC CONTROLLER

At the first four or five inspections after the equipments are put in service, the cap screws fastening the main cable connections to the contactors, line breaker, reverser and relays should be examined to insure they are tight.

With the PC controller, the line breaker shunts and contactor shunts, contact tips

and arc chutes as well as the control and reverse fingers and segments should be given particular attention. Valves and cylinders should be tried for air leaks. Relay contacts should be examined, and such parts as require it, lubricated.

Below is given a detailed description for the maintenance of these parts.

CONTACTORS AND LINE BREAKER

- (a) Examine contact tips and tighten screws holding them if loose.
- (b) Renew contact tips when worn half-way through.
- (c) When renewing a contact tip, if the surface against which it rests has become rough or pitted due to poor contact from a loose screw or similar cause, it should be smoothed up or else a new part installed.
- (d) The contact tips of the line breaker and contactors close with a butting and rolling movement, which tends to remove any roughness caused by arcing. If, for any reason, the tips get extremely rough, they should be filed smooth.
- (e) The screws holding the contactor and line breaker shunts should be examined to see that they are tight.
- (f) The contactor and line breaker shunts should be examined for wear and breakage.
- (g) Try the operation of the line breaker by pressing the valve operating pin. It should operate quickly either closing or opening in less than $\frac{1}{5}$ second. If sluggish, the cylinder should be oiled by placing approximately one teaspoonful of thin non-freezing oil, such as PC Control Lubricant No. 1, through the hole above the piston. This should be done at least once every three months, whether the car is run regularly or not or whether the breaker shows signs of slowness.
- (i) Oil all bearings, rollers and hinge pins with a thin lubricating oil, such as PC Control Lubricant No. 1.
- (j) The main cylinder should be oiled at least once every three months by removing the heads and placing a thin film of non-freezing oil, such as PC Control Lubricant No. 1 or No. 2 on the walls.
- (k) The PC-10, 11, 12 and 101 controllers are provided with three oil holes, A, B and C, as shown in section through main engine cylinder in Fig. 29. At every inspection a small amount of thin non-freezing oil,

such as PC Control Lubricant No. 1 should be put in A and B with the controller in the "off" position and in C when in the full "on" position. The PC-13 uses only holes B and C.

REVERSER

- (a) Inspect for weak fingers, poor contact and loose connections.
- (b) Clean contacts and lubricate with vaseline or a thin lubricating oil, such as PC Control Lubricant No. 1.
- (c) Operate the reverser by pressing on the valve pin. It should throw in less than one second. If slow, and segments and bearings are well lubricated, the cylinder should be oiled. The cylinders should be oiled at least every three months by removing heads and placing a thin film of non-freezing oil, such as PC Control Lubricant No. 1 or No. 2 on the walls.

CONTROL FINGERS

- (a) At each inspection, the control fingers on the reverser, line breakers and control drum and their segments should be wiped clean with a piece of cheese cloth that has been moistened with a thin lubricating oil. This is more essential when the control is operated from low potential (150 volts or less) than when trolley voltage is used.
- (b) The control fingers when in contact with a segment should have sufficient pressure to make a good contact.
- (c) The fingers should be replaced when worn half way through, thereby preventing delays to service from a broken finger.

OVERLOAD RELAY

- (a) Clean contacts when dirty.
- (b) Trip the relay and see that the armatures move easily.

CURRENT LIMIT RELAY

- (a) Clean contacts when dirty.
- (b) Move armature by hand and see that they are free and move easily.

CONTROL DRUM

When segments are replaced on the control drum, they should be located with respect to the control fingers. This is quite necessary, as the circuit, which controls the stopping of the cam shaft for each controller point, is broken by these segments and control fingers.

Where other information is not available, it is suggested that measurements between the control finger and the old segment be made before its removal and used in locating the new segment.

STAR WHEELS

The star wheels of the PC controllers, like those in a K controller, locate the controller notches. If the pawl springs are broken or become weak, the controller notches are not as definitely located as they will be when the spring pressure is normal.

When a large number of valves are to be ground in, the cost may be reduced by using special reamers on the valves and valve seats before the valves are ground in.

To grind in the INLET VALVE of the "off" magnet, remove the valve and its seat from the valve case and use the grinding

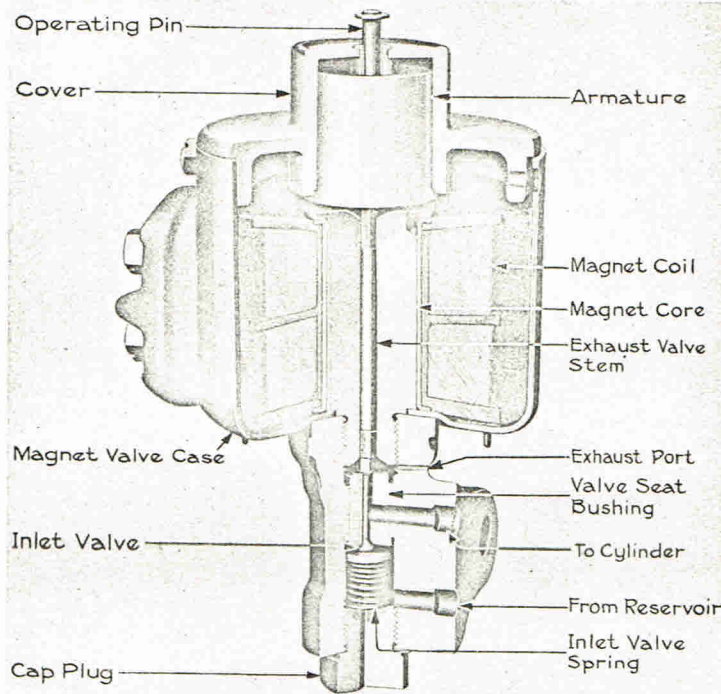

Fig. 41. Magnet Valve for Reverser, Line Breaker and "ON" Cylinder

The pressure of the pawl roller against the star wheel, with the controller in the "off" position, for the PC-5, PC-6, and PC-9 controllers should be between 13 and 25 pounds, and for the PC-10, PC-12 and PC-101 controllers should be between 20 and 30 pounds.

MAGNET VALVES

The general construction of the magnet valves used on the reverser line breaker and "on" cylinders is shown in Fig. 41, while the "off" magnet valve is shown in Fig. 42.

When the valves are sticky, wash with gasoline or kerosene, also pour a little gasoline through the magnet core to clean the valve seats. **When valves are removed, each must be returned to its own seat, as each stem is ground to fit its own seat.**

Whenever a new valve is installed, or a valve leaks, it must be ground in. After a good seat is obtained, blow out all grinding materials with air and wash with gasoline.

jig—Cat. No. 472536 (shown in Fig. 49). The screw threads in the jig form a holder for the valve seat, and the hole in the jig acts as a guide for the inlet valve. A thin paper gasket is used between the inlet valve seat and the valve case; be sure that this is in good condition before replacing the valve seat. The screw-driver—Cat. No. 189905, may be used for removing and replacing the inlet valve seat.

MEASURING AIR GAP AND TRAVEL

The air gap and travel of the magnet valves should be measured once a year. This measurement is made by removing the magnet valve cover and armature. The 0.020-in. gauge—Cat. No. 1408379, is placed around the upper valve stem or plunger and the armature pressed on top of the valve stem. The exhaust valve of the reverser, line breaker and "on" magnet valves should seat (that is, air should not escape through the exhaust valve). For the "off" valve,

this test should seat the inlet valve (that is, air should not pass through the valve). If air passes through, new valves must be installed.

inlet valve stem. If the upper valve stem is below the surface of the gauges, a new inlet valve with a longer stem should be put in.

3. Replace the 0.036-in. gauge with the

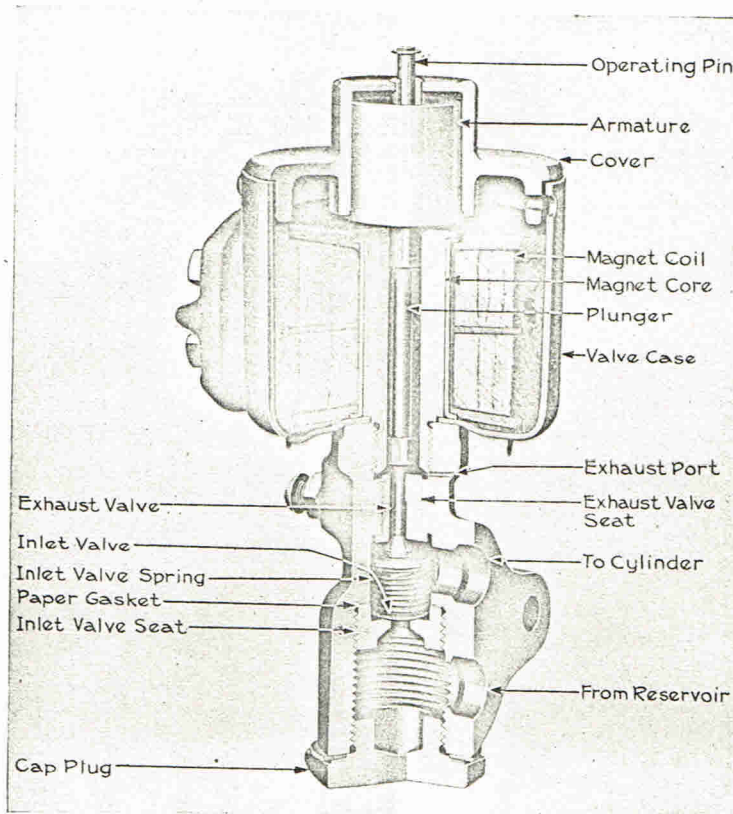

Fig. 42. Magnet Valve for "OFF" Cylinder

INSTALLING AND ADJUSTING NEW VALVES

REVERSER, LINE BREAKER AND "ON" MAGNET VALVES

1. Place the 0.052-in. gauge (Cat. No. 1408378) around the exhaust valve stem. Then press down on the valve stem. When the exhaust valve seats (that is, air does not pass through the valve), the top of the valve stem should be flush with the surface of the gauge. If it is not flush, it should be shortened or lengthened until it is flush.

2. Place the 0.036-in. gauge (Cat. No. 1408350) on top of the 0.052-in. gauge. If the inlet valve stem is the proper length, the upper or exhaust valve stem will be just flush with the gauges, and, when the armature is pressed down, no action will result (that is, air will not pass through the inlet valve). If the upper valve stem is above the surface of the gauges, a small amount should be filed off the

0.020-in. gauge, and press down on the exhaust stem with the armature. Air should pass through both the inlet and exhaust valves.

ADJUSTING "OFF" MAGNET VALVE

Small PC controllers equipped with accelerator valves to have adjustment as below except two 0.052-in. gauges instead of one 0.052-in. gauge and one 0.036-in. gauge.

1. Place the 0.052-in. and 0.036-in. gauges around the plunger. If the plunger and exhaust valve stem are the proper length, the top of the plunger will be flush with the gauges, and, when the armature is pressed down on the plunger, air will not escape from the exhaust valve. If the top of the plunger is above the surface of the gauges, either the plunger or the exhaust valve stem should be shortened. If the plunger is below the surface of the gauge, either the plunger or exhaust valve stem is too short and a new one should be used.

2. Remove the 0.036-in. gauge.

Press the armature on the plunger; this should seat the inlet valve (that is, air should not pass through the valves). If the valves are the proper length, the top of the plunger will be flush with the surface of the 0.052-in. gauge. If the plunger is above the surface of the gauge, remove the inlet valve seat and place additional paper washers between the

casting above the piston. The main and reverse cylinders by removing the pipe plug in cylinder head and squirting on the top wall of the cylinder. If pipe plugs are not provided, remove the cylinder heads and apply the lubricant with a swab.

4. Refer to Fig. 29, put PC Lubricant No. 1 in holes A and B with controller in "off" posi-

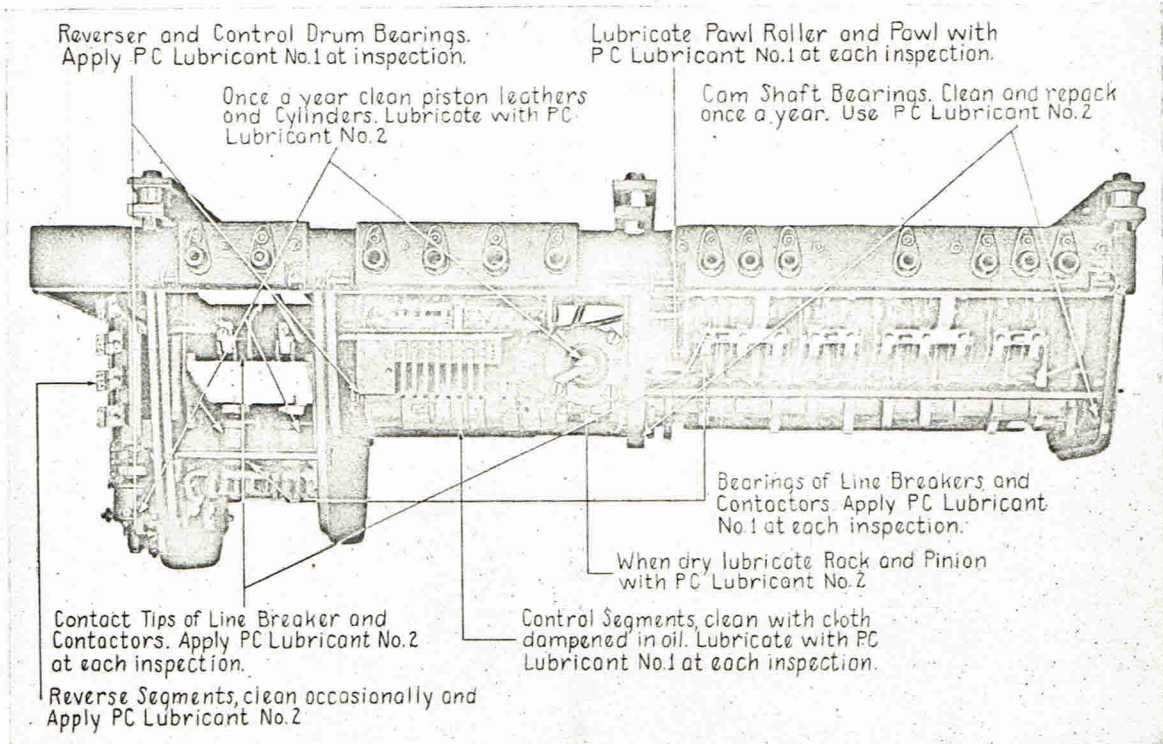

Fig. 43. Lubrication Chart for PC-10, PC-12, PC-13, PC-14, PC-101 and PC-102 Controllers

valve seat and valve casing until the top of the plunger is flush with the surface of the 0.052-in. gauge, with the plunger pressed down. If the top of the plunger is below the surface of the gauge, either use a new valve or make a metal washer, which should be placed between the inlet and exhaust valves, increasing the length between these valves.

LUBRICATION

Intervals of Three Months or Less AIR ENGINES

1. Lubricate all pneumatic cylinders with PC Lubricant No. 1, using one teaspoonful for each cylinder.
2. This lubricant can best be applied by means of an oil or grease gun.
3. The line breakers are lubricated by squirting oil through the hole in the cylinder

tion. Then turn controller to full "on" before putting it in hole C. The small controllers (PC-5, PC-6 and PC-9) have hole A omitted.

BEARINGS

1. The roller bearings on the contactor units and star wheel pawls should be lubricated with a small amount of PC Lubricant No. 1, applied at each end, and the bearing rotated to cause the oil to enter between the end washer and the outside rollway.
2. The hinge pin bearings of the line breaker and contactor units should be lubricated with a small amount of PC Lubricant No. 1.
3. Lubricate the reverser main bearings and also the sliding bearing and pin between the piston and the crank, if the controller is of the PC-10, 11, 12 or 101 type, with a small amount of PC Lubricant No. 1.

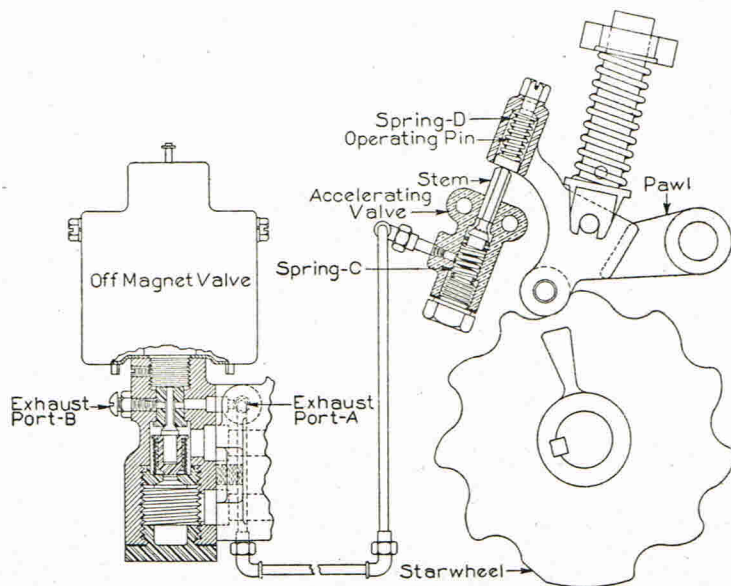

Fig. 44. Connections of Accelerator Valve on Small PC Controllers

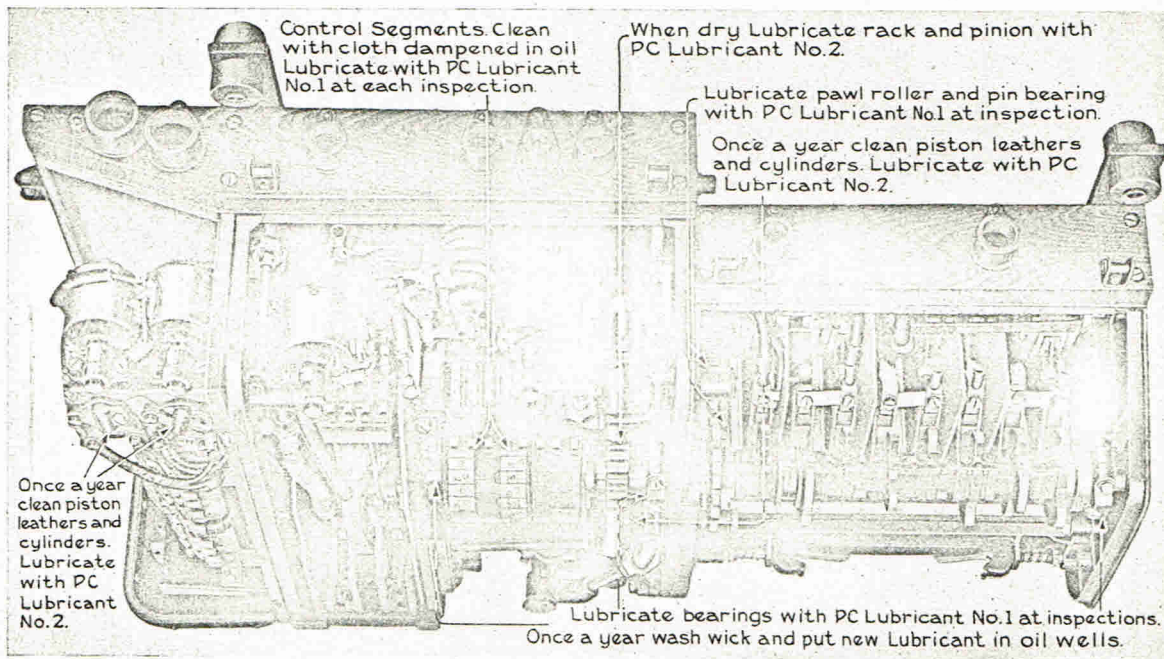

Fig. 45. Lubrication Chart for PC-5, PC-6, PC-9 Controllers

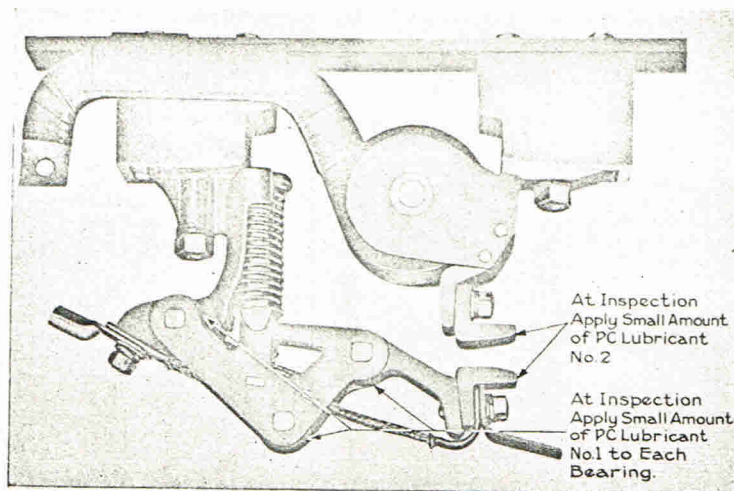

Fig. 46. Lubrication Chart of Contactor Unit

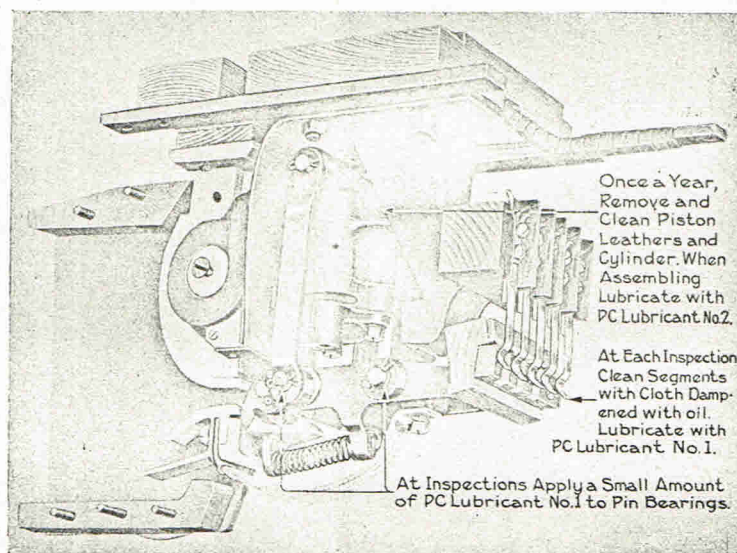

Fig. 47. Lubrication Chart of Line Breaker

OVERHAULING PERIOD AT LEAST ONCE A YEAR

AIR ENGINE

1. Dismantle the air operating cylinders sufficiently so that the cylinder walls and piston parts may be thoroughly cleaned. This should include for the large PC controllers (PC-10, PC-11, PC-12 and PC-101) removing and cleaning the spring and piston head in the "off" end of the main air engine as indicated on pages 22 and 23. When reassembling, lubricate with PC Lubricant No. 2. The three leather washers constitute a single packing and even when soaking them in oil should never be separated.

2. If the leather packing is soft and pliable rub it over with PC Lubricant No. 2. If the packing is dry and hard, soak it for several hours in PC Lubricant No. 1. Do not knead the leather to soften it as it distorts the packing with the possibility of leaking when reassembled.

3. Apply to the clean cylinder walls with a swab or brush an even film of PC Lubricant No. 2. For cylinders $3\frac{1}{2}$ in. diameter use $\frac{1}{5}$ -ounce (heaping teaspoonful). For cylinders $1\frac{3}{4}$ -in. and $2\frac{1}{4}$ -in. diameter use $\frac{1}{8}$ -ounce (level teaspoonful).

BALL BEARINGS

Remove bearing and bearing housing from the cam shaft and pry out the plate holding the bearing in the housing. Clean thoroughly, pack with PC Lubricant No. 2 and use new felt washers when reassembling.

SLEEVE AND SPHERICAL BEARINGS— (WICK OILED)

Clean the oil wells and bearings, wash the felt wick in gasoline rather than signal oil or kerosene. Fill with PC Lubricant No. 1.

ACCELERATOR VALVE FOR SMALL PC CONTROLLERS

When the controller is on a point and the star wheel roller is in a notch, as shown in Fig. 44, the accelerating valve is held open by the spring behind the operating pin. When the off valve is energized so that the controller will advance a point, the air exhausts rapidly through exhaust port "A" and the accelerating valve and the shaft starts to move in a very short time. As soon as it moves far enough for the roller to rise partly out of the notch, the accelerating valve stem closes

causing the air to exhaust through port "B," which can be adjusted by a screw. This slows up the movement of the shaft so that it will stop at the next point. As the roller drops into the next notch, the operating pin strikes the stem, but due to air pressure behind this stem the spring behind the pin is compressed and the valve remains closed. As soon as the off magnet valve closes and the pressure is removed,

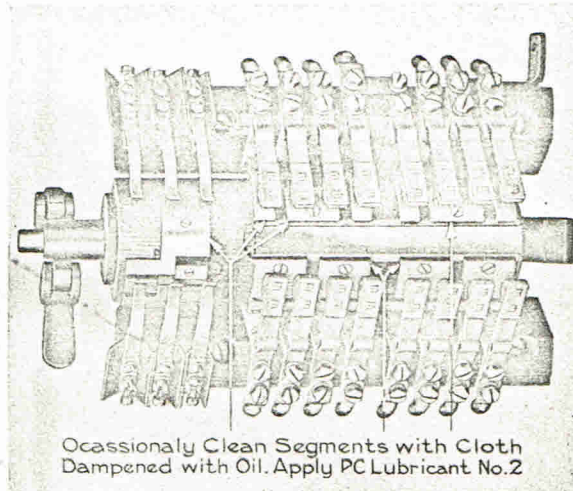

Fig. 48. Lubrication Chart of Reverser

the spring "D" pushes the pin and stem down and the valve is opened ready for the next operation. This spring must, therefore, be strong enough to operate the valve stem when there is no pressure behind it, but weak enough to be compressed when there is pressure. The stem should travel between $\frac{7}{32}$ and $\frac{9}{32}$ in. when the controller is operating in series. When turned all on the valve is open at the start, but closes as the roller comes out of the off position notch and remains closed until the controller reaches the full on position due to air pressure being maintained behind the stem. The speed of turning on is therefore regulated entirely by the adjusting screw in port "B."

GAUGES AND WRENCHES

Cat. No. 89996 (Fig. 49) wrench for turning cam shaft PC-5, PC-6 and PC-9 controllers.

Cat. No. 149761 is wrench for adjusting contact of reverser fingers.

Cat. No. 176773 is ring (16, Fig. 29) used when removing or replacing the piston spring (11, Fig. 29) in the main operating cylinder PC-10, PC-12 and PC-101 controllers.

Cat. No. 176775 is a pin wrench for the stud cap (9, Fig. 29).

Cat. No. 189906 is a double open-end S wrench, one end for $\frac{1}{4}$ -in. cap screw and the other end for $\frac{5}{16}$ -in. cap screws.

Cat. No. 189907 is a double open-end S wrench, one end for $\frac{3}{8}$ -in. cap screw and the other end for $\frac{1}{2}$ -in. cap screw.

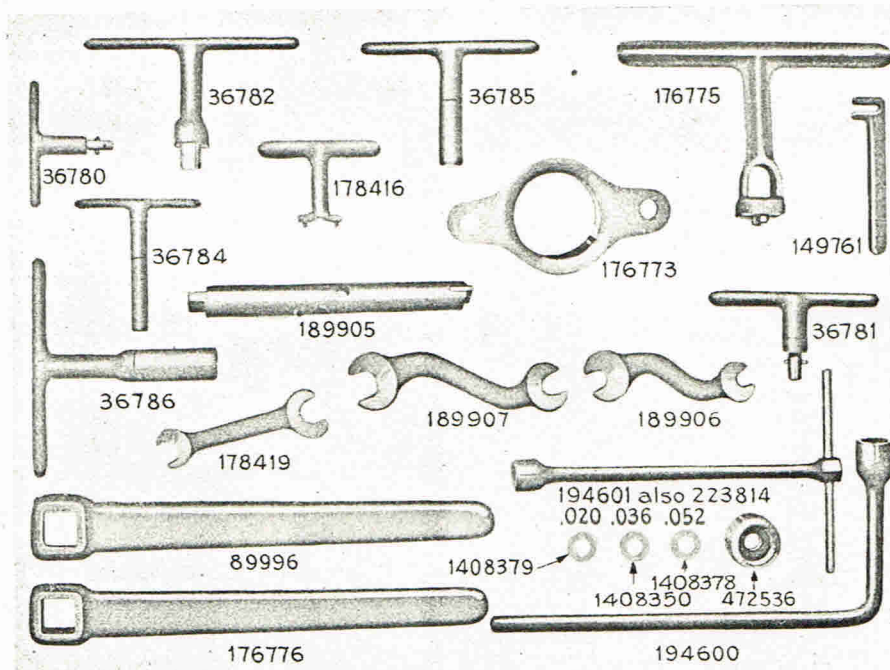

Fig. 49. Wrenches for PC Control Equipment

Cat. No. 176776 is a wrench for turning cam shaft PC-10, PC-12 and PC-101 controllers.

Cat. No. 472536 is a jig for grinding the inlet valve and seat or the "off" magnet.

Cat. No. 1408379 is a 0.020-in. gauge for measuring movement of the magnet valves.

Cat. No. 1408350 is a 0.036-in. gauge for measuring movement of the magnet valves.

Cat. No. 1408378 is a 0.052-in. gauge for measuring movement of the magnet valves.

Cat. No. 178416 is a spanner wrench for the magnet core nut in the magnet valves.

Cat. No. 178419 is a double open-end wrench, one end for $\frac{1}{4}$ -in. nuts and the other for $\frac{5}{16}$ -in. nuts.

Cat. No. 189905 is a screw-driver for the cap screw (10, Fig. 29) holding piston spring, and also for the inlet valve seat of the "off" magnet valve.

Cat. No. 194600 is a socket wrench for a $\frac{1}{2}$ -in. cap screw.

Cat. No. 194601 is a socket wrench for a $\frac{3}{8}$ -in. cap screw.

Cat. No. 223814 is a socket wrench for a $\frac{5}{16}$ -in. cap screw.

Cat. No. 36780 is for contact socket of train line couplers.

Cat. No. 36781 is for contact socket of $\frac{1}{2}$ -in. bus line couplers.

Cat. No. 36782 is for contact socket of $\frac{3}{4}$ -in. bus line couplers.

Cat. No. 36784 is for contact plug of train line couplers.

Cat. No. 36785 is for contact plug of $\frac{1}{2}$ -in. bus line couplers.

Cat. No. 36786 is for contact plug of $\frac{3}{4}$ -in. bus line couplers.

CABLES FOR CAR EQUIPMENT

The cables for car equipment have seven strands for all sizes smaller than No. 1 B.&S. gauge, while No. 1 B.&S. and larger have nineteen strands.

In the following table 1-Motor, 2-Motor, etc., indicate that the cable carries the current of a single motor in the former and of two motors in the latter case. The numbers are American wire or Brown & Sharpe gauge sizes.

CROSS SECTION OF CABLE FOR CAR EQUIPMENTS

H.P. of Motor at 600 Volts	TROLLEY AND GROUND CABLE		MOTOR CABLE		RESISTOR CABLE		
	2-Motor	4-Motor	1-Motor	2-Motor	1-Motor	2-Motor	4-Motor
25	5	2	7	5	7	7	6
40	4	1	6	4	7	6	4
50	4	0	6	3	7	6	3
65	3	00	5	1	7	5	2
75	1	000	4	0	6	4	2
100	0	0000	3	00	6	3	0
125	00	300000 CM	2	000	5	2	00
140	000	350000 CM	1	0000	5	1	00

CONDUIT SIZES

Nominal Size In.	Outside Diam. In.	Inside Diam. In.	No. of Threads per In. of Screw	Nominal Wt. per Ft.
1/2	0.84	0.62	14	0.85
3/4	1.05	0.82	14	1.12
1	1.31	1.04	11 1/2	1.67
1 1/4	1.66	1.38	11 1/2	2.24
1 1/2	1.90	1.61	11 1/2	2.68
2	2.37	2.06	11 1/2	3.61

**MULTIPLE CONDUCTOR TRAIN AND JUMPER CABLE
600 VOLTS. EACH CONDUCTOR 19/25**

No. of Conductors	Diam. Over All In.	TRAIN CABLE		JUMPER CABLE	
		Conduit Size In.	Approx. Wt. per 100 Ft.	Diam. Over All In.	Approx. Wt. per 100 Ft.
7	0.75	3/4	32	0.97	54
9	0.875	1	43	1.03	64
10	0.906	1	48	1.06	70
12	1.06	1 1/4	55	1.28	89

TYPE C-6 FEED VALVE

This valve is used to maintain a constant pressure in the control pipe.

DESCRIPTION OF VALVE

A slide valve, operated by a piston, controls a port leading from the low pressure or control pipe side of the valve to the valve

A regulating spring acts against the pressure on the diaphragm. Its compression, which determines the control pipe pressure, can be readily changed by means of an adjusting screw.

OPERATION

When the valve is closed the pressure in the main reservoir and piston chamber is equal and the pilot valve is closed by its

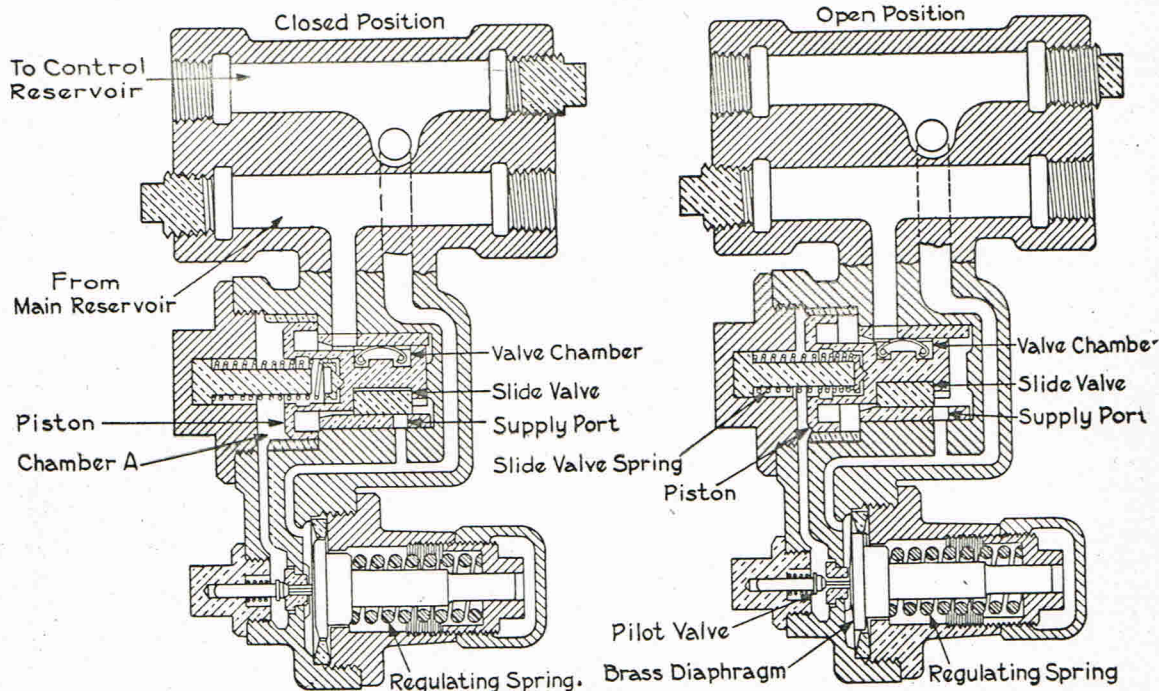
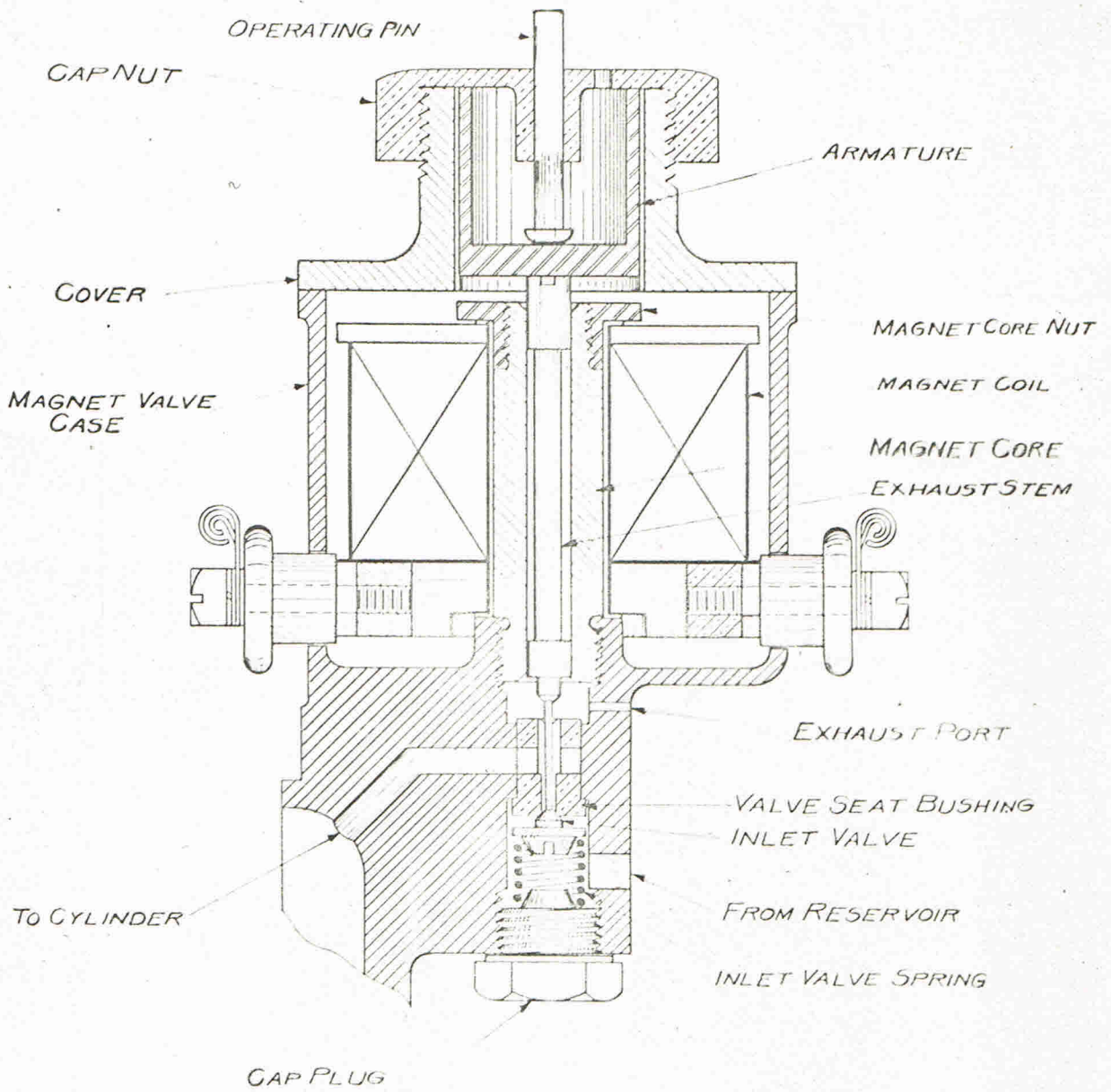

Fig. 50. Instruction Diagram of Slide Valve Feed Valve Mounted on Combined Straight and Crossed Passage Pipe Bracket

chamber. See Fig. 50. The valve chamber is in communication with the main reservoir or high pressure side of the valve. The piston which carries the slide valve is fitted loosely in the valve casing, allowing air to leak around it, so that any difference in pressure between the two sides is quickly equalized. A small pilot valve, actuated by a brass diaphragm, governs a port leading from the piston chamber at the back of the slide valve piston to the chamber on the pressure side of the diaphragm, the latter being connected to the low pressure or control pipe side of the valve.

spring, the diaphragm being deflected by the control pipe pressure. If the pressure in the control pipe falls, thereby reducing pressure on diaphragm, the pilot valve opens and reduces the pressure on the piston chamber side of the piston. The piston then moves, opening the supply port and making connection between the main reservoir and control pipe. This connection continues until the pressure in the control pipe is sufficient to deflect the diaphragm and allow the pilot valve to close. The pressure then quickly equalizes on both sides of the piston and the supply port is closed by the action of the slide valve spring.



234829

MAGNET VALVE FOR REVERSER, LINE BREAKER AND "ON" CYLINDER.

INDEX E-353.7

3

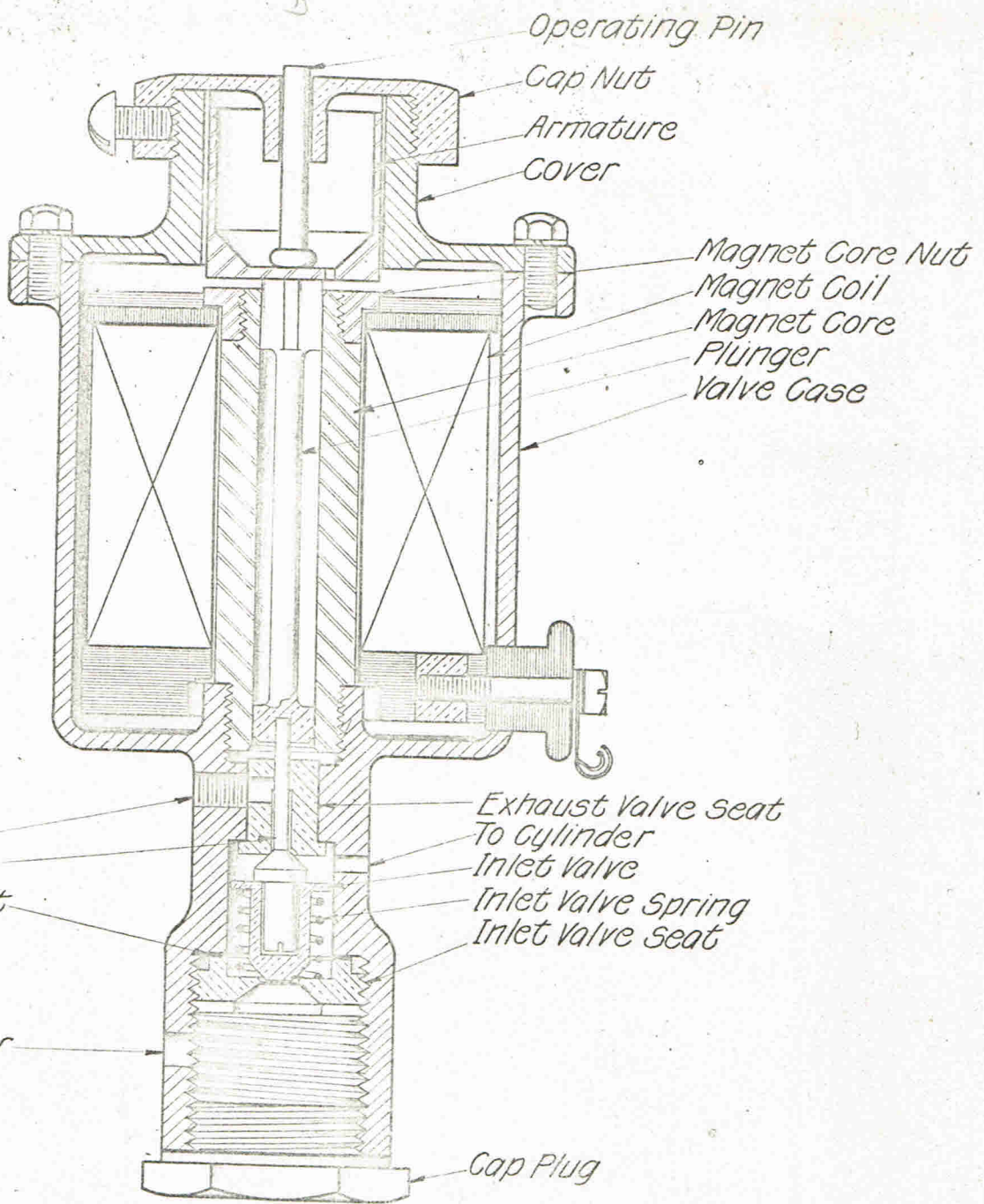

2-7836

MAGNET VALVE FOR "OFF" CYLINDER

INDEX TO PARTS

11-11